



SLEIPNER[®]

Ocean born. Tech bred.

THRUSTERS | STABILIZERS | STEERING | WINDLASSES

Our story

We are a Norwegian technology driven company, focused on creating world leading products and solutions of uncompromised quality to improve safety and comfort at sea. As boaters we know what safety at sea *means*.

So, we don't let our solutions slip out of sight for a second; We manufacture them ourselves, using technologies we have developed ourselves – and we work in close partnership with boat builders and our global service network to ensure optimal function throughout their lifetime.

You know what you get when you install a Sleipner. Our dedication to boating and innovation ensures that our solutions are the benchmark for the industry, today and tomorrow.



Trustworthy • Knowledgeable • Future ready

— This is Sleipner —

Established in Norway in **1908** with more than **115 years of experience**. Sleipner has 200+ employees, including **29 engineers** with more than **260 years combined experience** in the marine industry.

45

Third party sales and service organizations in **45 countries**.

18

18 CNC operators with more than **230 years** combined marine experience.

7

7 subsidiaries providing sales, support and after sales services.

5

Strategic technology partnership with **5 external specialists**.





The boat builder's choice

Leading boat builders worldwide choose Sleipner for performance, reliability, ease of installation, and unrivaled safety features. This commitment to quality and product development has made the Sleipner range of thrusters the industry benchmark.

The world's finest reference list

Our focus on quality, reliability, and continuous improvement has led an overwhelming number of the world's leading boat brands to our customer list. Sleipner solutions are also

chosen onboard pilot boats, commercial fishing vessels, navy patrol boats, passenger ferries, and more because of their supreme quality and performance.

”

When choosing a Sleipner product, you choose a product invented, engineered, and manufactured for boaters - by boaters.

CEO Ronny Skauen

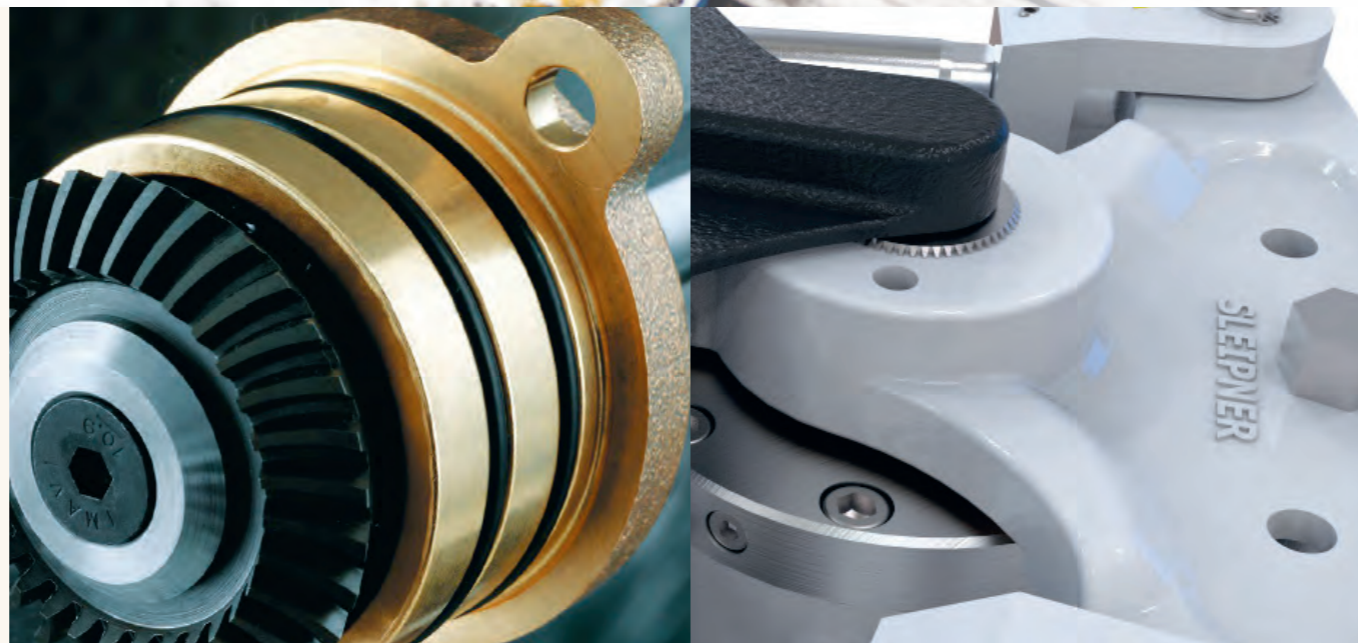

The result of over **115 years of experience.**
Made in Norway.



SLEIPNER

Stabilizer systems

Sleipner's Vector fins™ is the only top performing stabilizer system for both cruising and at anchor-use. The fins' patented, unique shape reduces drag and improves fuel efficiency – translating more of their power into actual roll stabilization. Enhanced comfort and safety with none of the drawbacks from flat fins.

Available in hydraulic and electric versions.



Vector Fins™ systems

Superior stabilization in every situation

Stabilizer systems have been used on larger passenger ships and superyachts for a long time. With ever more compact and efficient systems, boat owners can now enjoy the better usability and comfort on leisure vessels of all sizes.

What can stabilizers do for you?

Stabilizers reduce the roll movement of a vessel, which is in most situations by far the most dominant and most uncomfortable motion. So reducing roll by a good percentage will make a substantial difference in comfort and safety on board.

However, it is not always so clear what type of stabilization system to choose because the two leading technologies (fins and gyros) have significant functional differences, meaning that no one type suits all boats or all owners' cruising priorities.

Key things to consider

- Choose the right stabilization technology to match the type of boating you do.
- Check the practical limitations of your boat – not all systems will fit all boats, mainly due to space limitations.
- Consider what is best suited to your boat and what is likely to retain the most value when the time comes to sell – some sizes and style of boat lean more towards one technology than another.

Understanding the basics

The roll forces depend not just on the wave height but also on the time during which it affects the boat (wavelength). Another big factor is the speed of the boat: $\text{force} = \text{speed}^2$. Gyro-type stabilizers are installed inside the boat and get their total roll reduction force from the precession motion that they generate to resist the roll of a boat. They have the same total force regardless of wave period and boat speed with limited force.

Fin stabilizers on the other hand act in the water and have two ways of creating roll reduction force, depending on the boat's speed. At zero speed or 'at anchor' mode, the fins rotate rapidly (flap) to generate force and like the gyro, have a definite limit. However, when the boat is moving forward, fins also generate roll reduction forces by the angle at which they pass through the water, like adjustable airplane wings or underwater foils. This force increases by speed squared, so the faster the boat moves, the more force they generate.

Vector Fins™ stabilizers

- Unlike Gyros, efficiency increases with speed
- Minimal to no increase in fuel consumption
- Minimal to no loss of speed
- Silent all night operation
- Minimal internal space requirement
- Also suitable for retrofit

Which system is right for you?

If your only priority is having stabilization at zero speed, with these size choices, the gyro will eliminate more roll than the fins when anchored. However, if you also use your boat on longer cruises and want to have excellent stabilization when cruising in the open sea between sheltered anchorages, fins have a colossal force benefit. They can reduce or eliminate many times the wave height and length of a gyro of this size.

Typically
55%
less side
effects

Typically
50%
more efficient



Boat owner John Maxey on his experience with Sleipner Stabilizers.

”
It is like riding on a
Magic Carpet



Performance of different stabilizer technologies

A stabilizer system with Vector Fins is the only system that effectively handles both cruising and at anchor situations.

Due to their design, gyro stabilizers provide a constant force to stabilize a yacht, while fin stabilizers increase the forces by the square of the speed which makes a big difference.

Vector Fins are up to 30% more efficient when cruising and up to 50% more efficient when anchoring. Unwanted additional effects in terms of yaw and swaying can be reduced by up to 55% compared to flat fins.

Gyro stabilizers require a start-up time of 30-45 minutes until they function optimally and are more suited for anchoring due to their construction.

How to choose the right stabilizer for your boat

Over the last few years, roll stabilization has become a must-have for boat owners due to the impressive increase in comfort it delivers. The dramatic roll reduction modern systems provide also increases safety onboard and as a result, allows many families to get more use out of their boats.

If your only priority is having stabilization at zero speed, with these size choices, the gyro will eliminate more roll than the fins when anchored. However, if you also use your boat on longer cruises and want to have excellent stabilization when cruising in the open sea between sheltered anchorages, fins have a colossal force benefit. They can reduce or eliminate many times the wave height and length of a gyro of this size.

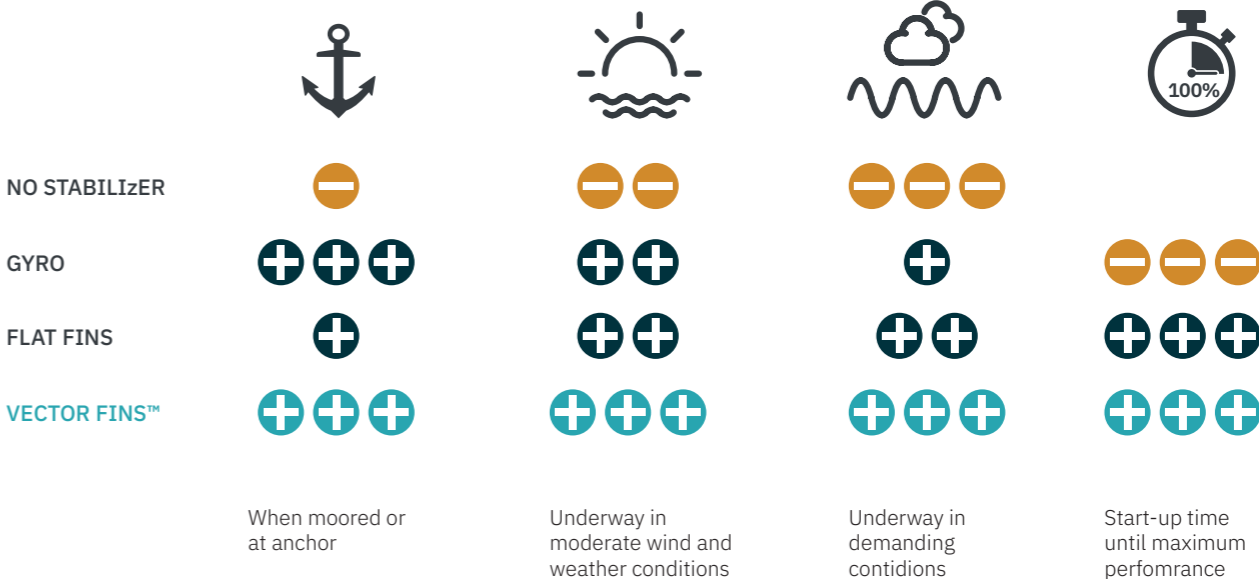

A stabilizer system with Vector Fins™ is the only system that effectively handles both cruising and at anchor situations.

Vector Fins™

- it's all about the physics

Most boaters who have ever had a stabilised boat would never buy another boat without. Most stabilizer systems on the market today will make a huge impact on onboard comfort, safety and second hand boat value.

However, there are important technological and efficiency differences that must be considered to choose the optimal system for a given boat.

The two most common roll reducing systems on the market today are gyro and fins. It is well established that fins are better for those who want effective stabilization both at anchor and underway, while gyro is good choice for boaters who are primarily focused on at anchor stabilization. The reason is that gyro stabilizers has a maximum stabilization force while fins will increase their stabilising efficiency with speed by a factor of 2.

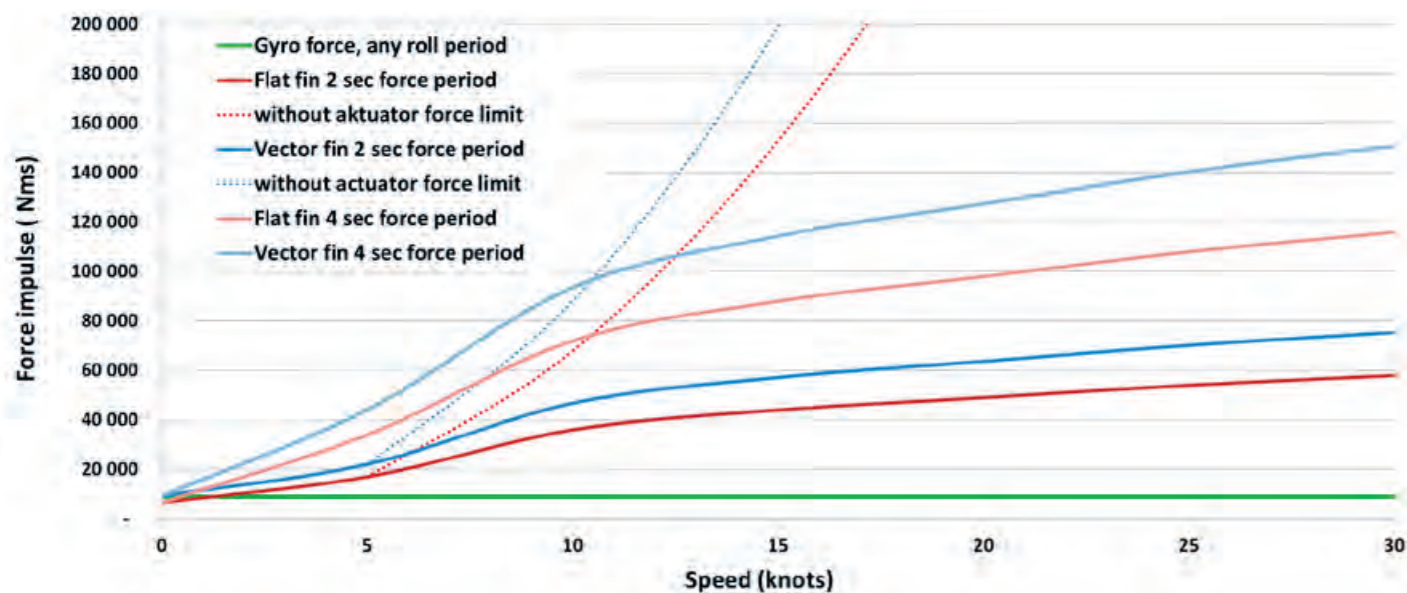

The sleek and curved fins have minimal direct drag and winglets to avoid wingtip vortex creation.

Curved Vector fins also generate lift at speed, helping to offset drag.

Verified stabilization test results Princess 56 with VF600 0,6m² Vector Fins™



	No stabilizer	Vector Fins™	Reduction of roll	Reduction of seasickness
Cruising at 11 knots				
Maximum roll movement	10.4°	0.3°	97%	99.8%
Average roll movement	5.7°	0.15°	97%	99.9%
At Anchor				
Maximum roll angle	9.4°	2.6°	72%	92%
Average roll angle	4.1°	1.4°	66%	88%

Vector Fins™

The most efficient stabilizer system on the market

Rolling around at sea is something most people will prefer to avoid if they can. With the modern stabilizing systems available on the market today, they do reduce the risk of becoming seasick by 80-90 percent.

Another aspect worth considering is plain and simple onboard safety.

Let's forget about seasickness and general onboard comfort for a while. A roll of just a few degrees impacts your footing onboard. Unexpected swells catch you off guard and send objects flying around. We've all been there. A stabilized boat is a very different base in terms of both perceived and actual safety.

Over the last few years, roll stabilization has become a must-have for boat owners due to the impressive increase in comfort it delivers. The dramatic roll reduction modern systems provide also increases safety on board and as a result, allows many families to get more use out of their boats.

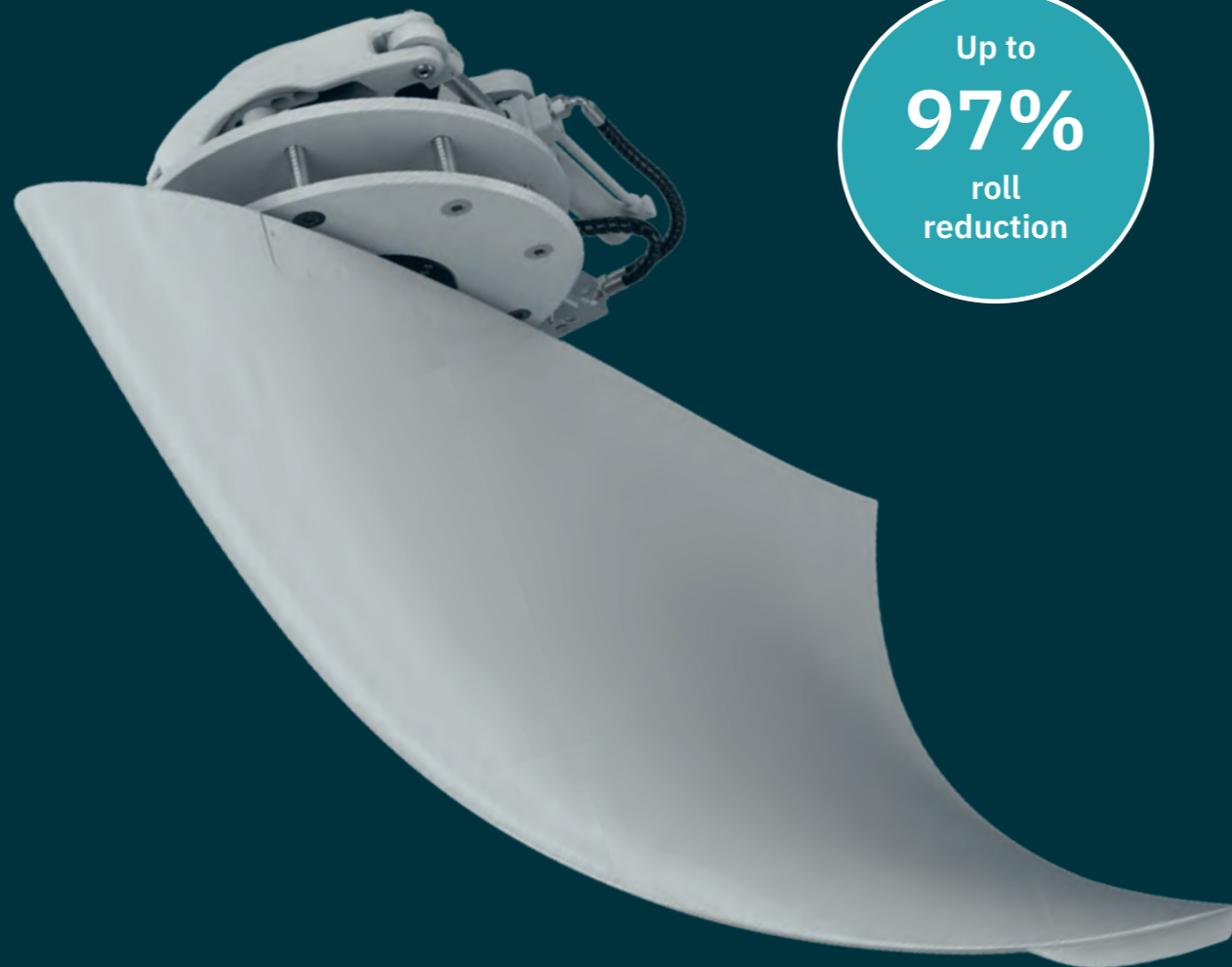

Up to
97%
roll
reduction

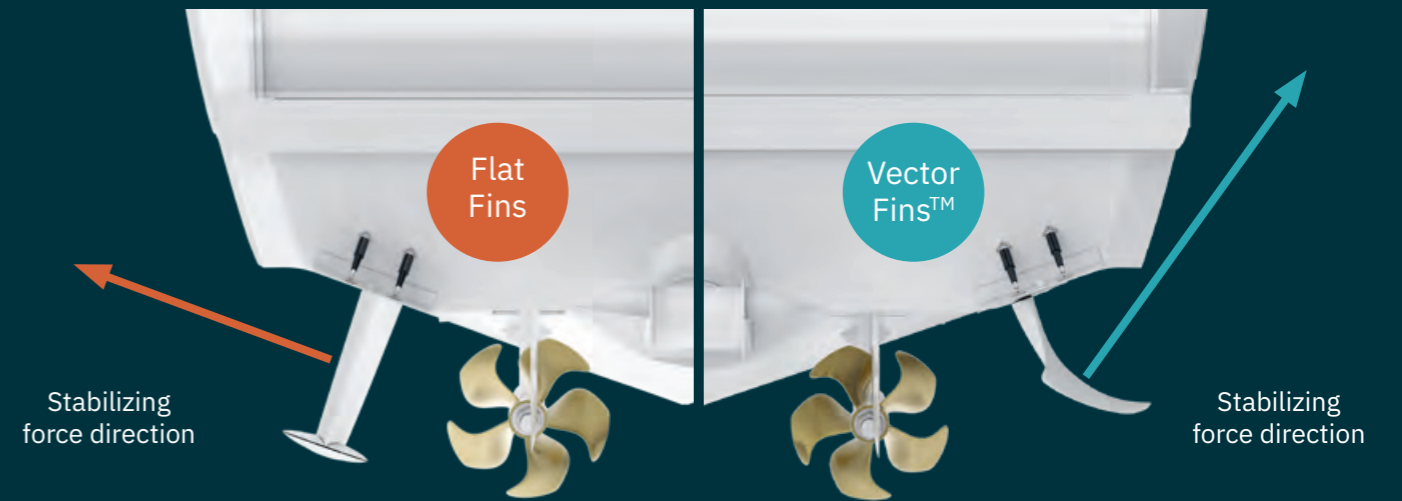
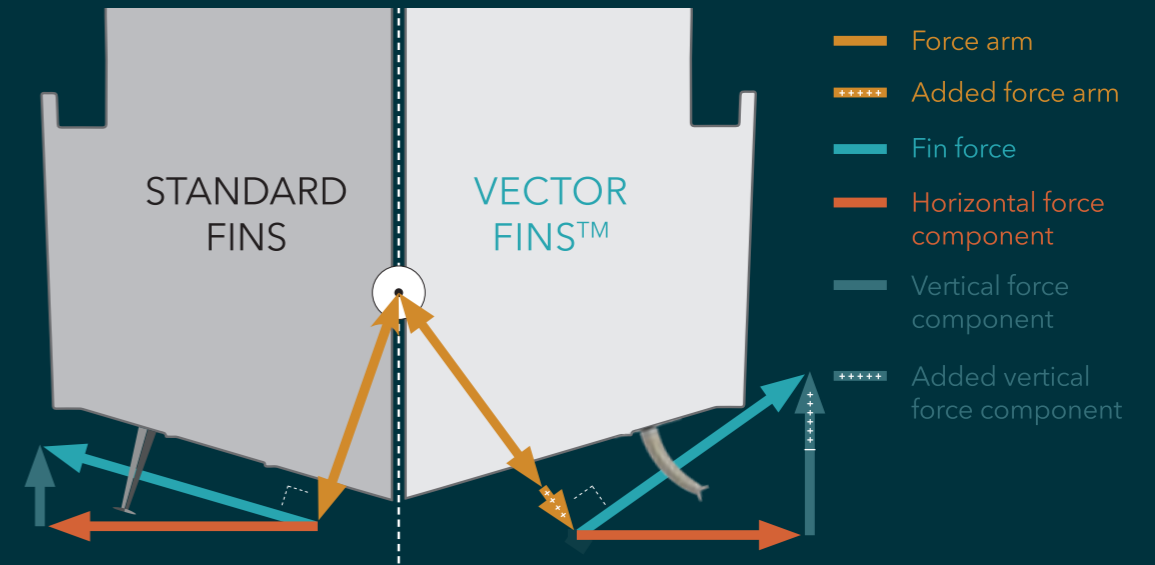

This simplified illustration shows how the Vector Fins™ better directs the fin forces toward the desired vertical direction, minimizing the energy waste of too many forces being used in the horizontal plane, which can cause unwanted side effects such as yaw and sway.

Vector Fins™ – a revolutionary generation of fin stabilizers

Fin stabilizers is the only system that handle well both cruising and “at anchor” use, with the “at anchor” stabilization force deciding the size of the fins.

Vector Fins™ – a simple solution to a complex problem!

The Vector Fins™ stabilizers dramatically improve the roll reduction efficiency while at the same time reducing undesired yaw and sway motions caused by active fins.

The fins are made as a “one shot” vacuum injected vinylester process over pre-shaped core material in a closed mold method.

Designed with rowing and mat layers to ensure maximum strength and minimum weight. Can even withstand minor damages without totally disintegrating afterwards, unlike traditional production methods often allows.

Underway

Unlike Gyro stabilizers that always have

the same maximum total force they can apply to reduce roll, independant of boat speed or roll periods, fin stabilizers increase their stabilization force by both speed and roll period when “cruising”.

At Anchor

As most boat owners spend more time at anchor than underway, it is critical that the stabilization system performs well at any speed, including no speed.

A stabilized boat offers a significant increase in onboard well-being. Moving around, getting the tender out, serving dinner or just getting in and out of the water for swimming becomes a lot easier and safer from a stabilized boat.

Spend those amazing nights at anchor under the stars in a bay - instead of a busy harbour!

Vector Fins™ benefits

- Up to 50% more efficient than flat fins
- Up to 55% less side effects than flat fins
- Advanced hydrodynamic fin design
- 20% – 50% less resistance than other fins, results in > virtually no loss of speed and thereby no added fuel consumption
- All fins are prepared for high efficiency in “Any Speed” – 2:1 size ratio, also “At Anchor”
- “one-shot” vacuum injected vinylester process
- rowing and math layers to ensure maximum strength

Typically
55%
less side effects

Typically
50%
more efficient

Product features

- S-Link™
- ANYSPEED
- HYDRODYNAMICAL SHAPE
- INSTANT-ON (MAX POWER AT START-UP)
- POWER SAVE MODE (AC POWER REDUCTION AT ANCHOR)

Technical details

Ideal Vessel Class	Yacht , Superyacht, Motor Boat
	Commercial vessel
Ideal Vessel Size	15–45m / 50–150ft
Power	Electrohydraulic System
Rated Power	3,5–15 kW
Actuator Position	360°
Shaft Positions	At anchor / Balanced / Underway

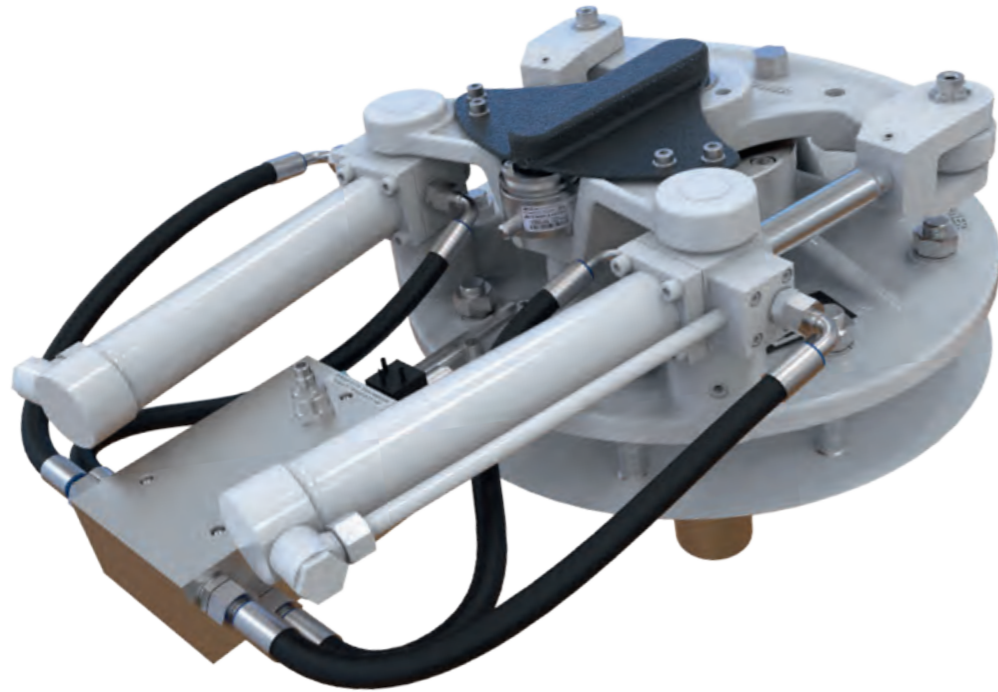

Advantages of a centralized hydraulic power system

- High efficiency for moving and holding high loads
- Proven and reliable technology
- Most used power system on boats from 60-70 feet and larger
- Can power many applications from one central hub
- Low maintenance
- Silent operation

Hydraulic actuators

The height inside the boat is often the key measurement to allow for installation in modern boats. The Sleipner actuators are typically 25% to 75% lower than others. They are constructed for easy installation and minimal noise reproduction.

Technical design benefits

- Precision machining and assembly ensures a long lifetime and durability.
- No additional center lock, this is automatic in the standard hydraulic system – very safe due to the hydraulics having extreme safety limits.
- Dual cylinders provide
 - balanced load unlike single cylinder solutions.
 - less bearing load, thereby allowing for a more compact shaft bearing assembly.
- Purpose-designed dual shaft sealing - superior to standard Simmer Ring lip seals.
- Internal hydraulic connections on actuators are pre-fitted from factory, the installer only connects non-moving hoses/ pipes - Easier and safer.
- No complex adjustments required to set up controller with lots of factors, these are set automatically on first seatrial of the boat.
- Most stabilizer systems require you to periodically service

- their bearings, meaning either a part change, lubrication and/or mechanical adjustments. Sleipner's latest generation of bearings do not need any of that, saving time and money for the owner with lifetime lubricated high-end bearings as standard, meaning one less service point on your vessel.
- Fins are installed and removed very easily and quickly from the outside for best convenience in transport or other haul-out situations where this might be needed.
- Defined shaft-shear point in case of the fins accidentally hitting something.
- All exterior parts are in stainless steel.

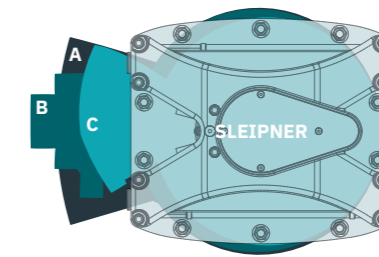
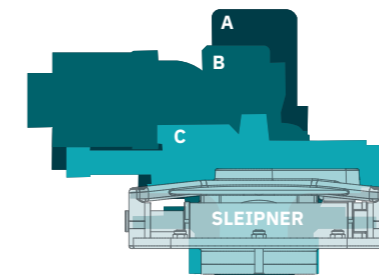

Size of Sleipner actuators compared to other brand actuators for similar fin sizes

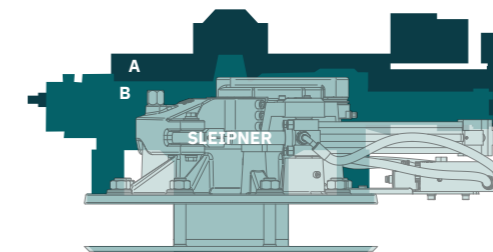

Sleipner actuators

The most compact actuator

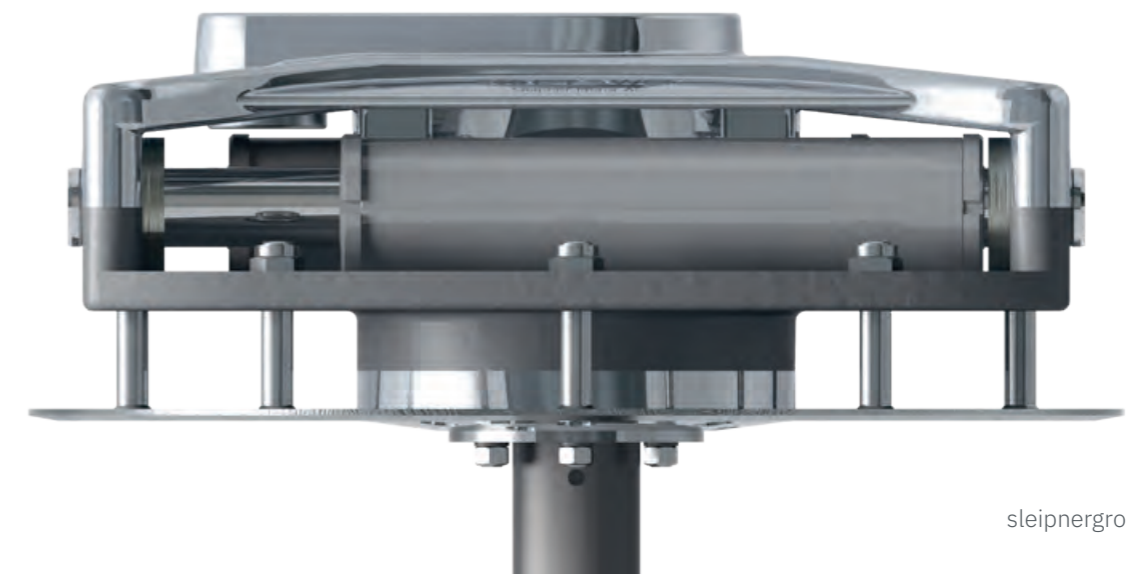

Compact, quiet and easy to install



Hydraulic Power pack for standalone installations

This a complete hydraulic power unit (HPU) for installations where the vessel does not have a hydraulic thruster system. All of the hose and wire connections are pre-installed, allowing for faster system install and startup in the field. All connections are focused on two sides of the tank, allowing installation in confined spaces.

We also offer pre-connected and easy to install central hydraulic systems with S-Link™ CAN bus system.

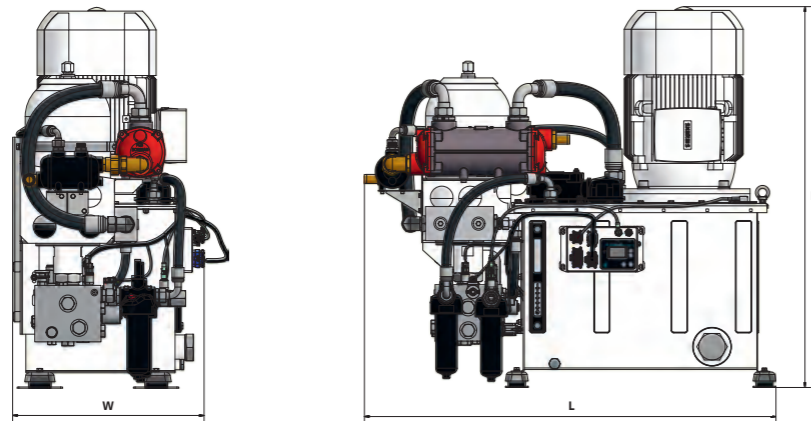

Power pack	10 4435C-W-01	10 4450C-W-01	10 4455C-W-01	10 44110C-W-xx-xx	10 44150C-W-xx-xx
Rated power (kw)	3.5	4.6	5.5	11	15
Weight (kg • lbs)	111 • 245	116 • 256	135 • 298	300 • 661	312 • 687
L (mm • in)	726 • 28.6	726 • 28.6	780 • 30.7	1087 • 42.8	1087 • 42.8
W (mm • in)	432 • 17	432 • 17	465 • 18.3	506 • 19.9	506 • 19.9
H (mm • in)	762 • 30	756 • 29.8	790 • 31.1	1006 • 39.6	1006 • 39.6
Generator load (kVA)*	4.6	6	7	13	18
For fin size (short r. p.)*	VF650 (SPS55)	VFS800 (SPS55B)	-	VFS1450 (SPS93B)	VFS1650 (SPS93B)
For fin size (long r. p.)*	VF650 (SPS55)	VFS800 (SPS55B)	VF1050 (SPS66B)	VFS1450 (SPS93B)	VFS1650 (SPS93B)

* Single phase supply will increase current with factor 1.73 and will require more margins on generator capacity.
 * ECO mode available in new 2018 control system for reduced generator load.
 xx-xx - available in 230V 1-phase, 230V 3-phase and 400V configuration.

* Short r. p. = Short roll period
 * Long r. p. = Long roll period
 Roll period is the time between two waves



Courtesy of Ferretti Group



DMC-SCU Dynamic Motion Controller TP-43

4,3" Sunlight color touch panel for ease of use and control. Multiple Control panels can be installed in one system.

Features

- Continuous development of the best control software possible, cooperating with leading companies in control technologies.
- Self adjusting – advanced algorithms – also “Any/No Speed” functions for stabilization at anchor.
- Easy upgrade of software ensures future compatibility and improvements.
- Reverse gear position input, but also other sensors to safeguard that fins are centered and locked immediately if the boat is starting to move backwards.
- GPS speed input (no shaft sensor) helps control algorithms do the best possible job.
- S-Link™ integrates common intelligence with thruster systems and main hydraulics.
- Can be flushed mounted.

Built in Wi-Fi module:

- Enables for software upgrades for the S-Link™ system without additional compute tools or service technicians
- Allows for faster support as service technicians can remotely access the control system upon request

Hydraulic Vector Fins™



Vector Fins™	VF650	VFS800	VF1050	VFS1450	VFS1650	VFS1950
Any speed stabilizing	Yes	Yes	Yes	Yes	Yes	Yes
Instant on	Yes	Yes	Yes	Yes	Yes	Yes
4-fin configuration	Yes	Yes	Yes	Yes	Yes	Yes
Industry leading efficiency	Yes	Yes	Yes	Yes	Yes	Yes
Coordinated turn control	Yes	Yes	Yes	Yes	Yes	Yes
Performance priority*	-	-	-	-	Yes	Yes
AC Power Save Mode	Yes	Yes	Yes	Yes	Yes	Yes
Compatible actuator	SPS55B	SPS55B	SPS66B / 67B	SPS92B	SPS93B / 94B	SPS96B / 97B

* Fins with the performance priority feature allows for at anchor stabilization, balanced or high-speed performance optimisation.

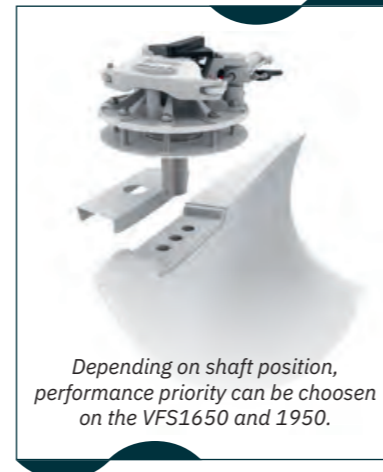
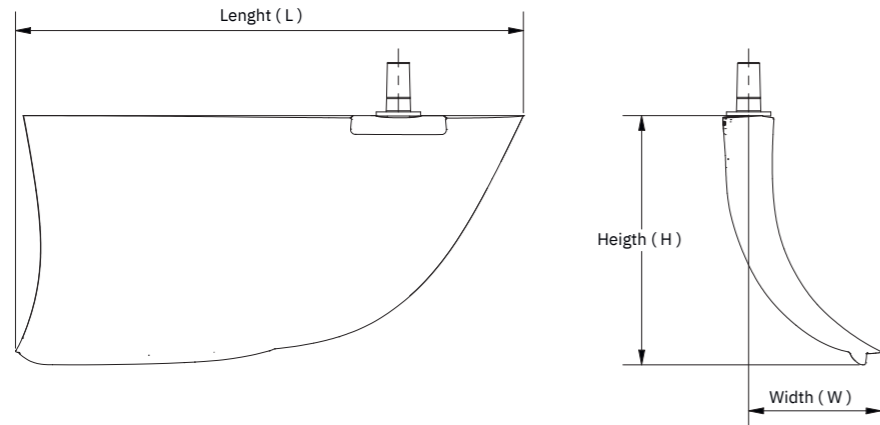

Vector Fins™ (mm)	VF650	VFS800	VF1050	VFS1450	VFS1650	VFS1950
(H) Height	667	718	847	947	1010	1098
(L) Length	1270	1463	1618	1925	2056	2235
(W) Width	337	381	427	502	537	583
Size (m ²)	0,65	0,80	1,05	1,45	1,65	1,95
Weight	0 weight in water	0 weight in water	0 weight in water	0 weight in water	0 weight in water	0 weight in water

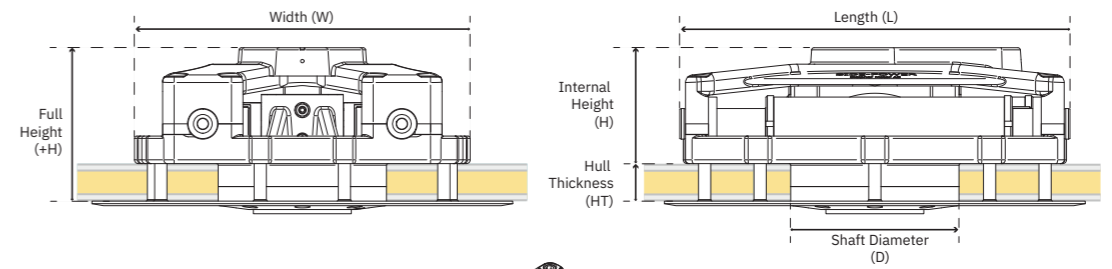

Measurements SPS55B

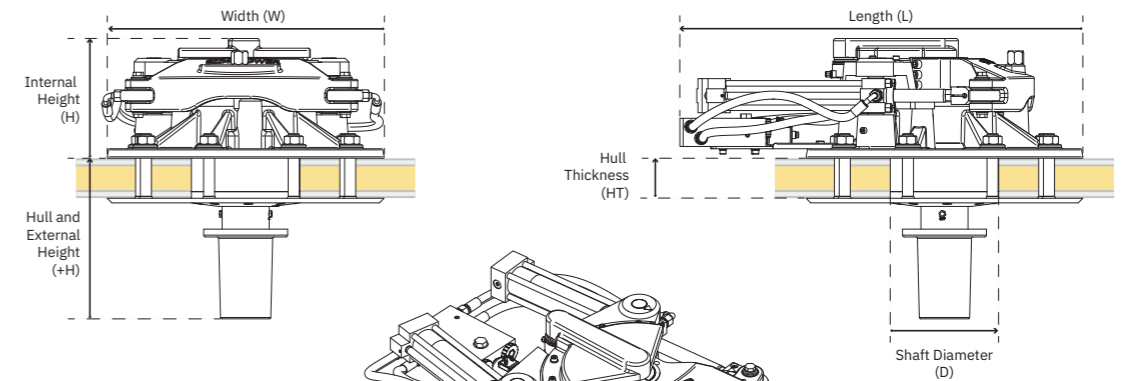
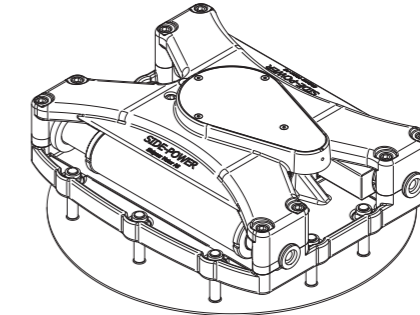

Measurements SPS66B / 67B / 92B / 93B / 94B / 96B / 97B

For metal framed boats extra actuator available

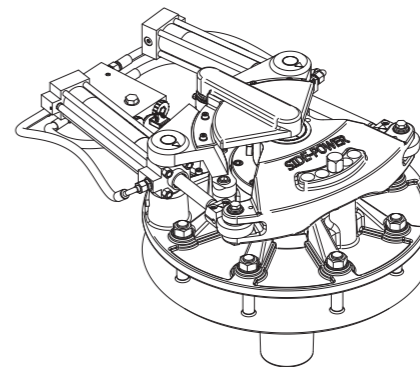

Actuator (mm)	SPS55B	SPS66B	SPS67B-167	SPS67B-208	SPS92B	SPS93B	SPS94B	SPS96B	SPS97B
(H) Height	152	192	191	191	265	265	260	260	260
(+H) Additional Height	-	319	408	450	347	346	496	346	496
(L) Length	510	773	773	770	871	871	871	873	874
(W) Width	440	550	550	550	700	700	700	700	700
(D) Diameter	220	175	175	175	235	235	235	235	235
(HT) Hull Thickness	49	72	160	202	87	87	239	87	239
Weight	100	105	114	114	185	185	190	185	190

Electric Vector Fins™ stabilizer system

NEW

A more sustainable choice

Vector Fins™, with their unique and patented design, direct their forces in a much more efficient direction than flat fins for roll stabilization. This benefits stabilization in anchoring and cruising situations. The fins also create lift while cruising, reducing the drag of the boat's hull.

Practically speaking this means that:

- The top speed of the boat will be higher than with flat fin stabilizers
- You will use less fuel than with flat fin stabilizers
- You will consume much less energy from your generator or batteries to achieve the same stabilizing forces at anchor

Quiet operation

The new Sleipner electric actuator solves the challenge of structural born noise from electric or electro-mechanic actuators. The patented solution isolates the moving, mechanical high-torque gears and motor from the boat reducing about 92% of structural born noise.

Sleep on it!

”

The third generation Vector Fins™ typically doubles the stabilizing force per kW input compared to flat fins at anchor.

CEO and Head of R&D
Ronny Skauen



The result of over
**1600 installations and 14
years of research.**
Made in Norway.

Significantly more effective

No one can tackle the climate challenges alone, but we can all contribute. The 3rd generation Vector Fins™ are more efficient underway and at anchor. For faster boats the lift from the fins results in improved fuel efficiency compared to flat fins. The fins consume extensively less energy at anchor to achieve the same stabilization level as flat fins. By using the same energy, they stabilize more.

Better for you, better for the environment

- Significantly more stabilizing forces and comfort at anchor
- Effective stabilization from 0 to 40 knots
- Improved speed and fuel efficiency
- Dramatic reduction in known negative side effects with flat fins
- Patented noise cancellation, eliminating up to 92% of structural born noise

It's all about physics

In 2013 Sleipner won the most prestigious award in the marine industry for the invention of the Vector Fins™ stabilizers. The patented, curved shape fins improve every aspect of stabilization compared to flat fins.

Where flat fin stabilization systems waste energy creating unpleasant sideways movements of the boat, Vector Fins™ generates much more vertical forces, which in the end, is what works to stabilize the boat the most effectively.

The same size Vector Fins™ will have the ability to stabilize the yacht in larger waves, or it will stabilize better in similar waves. At anchor, it will feel more comfortable, which is what stabilization is all about, as the boat has less yaw and sway.

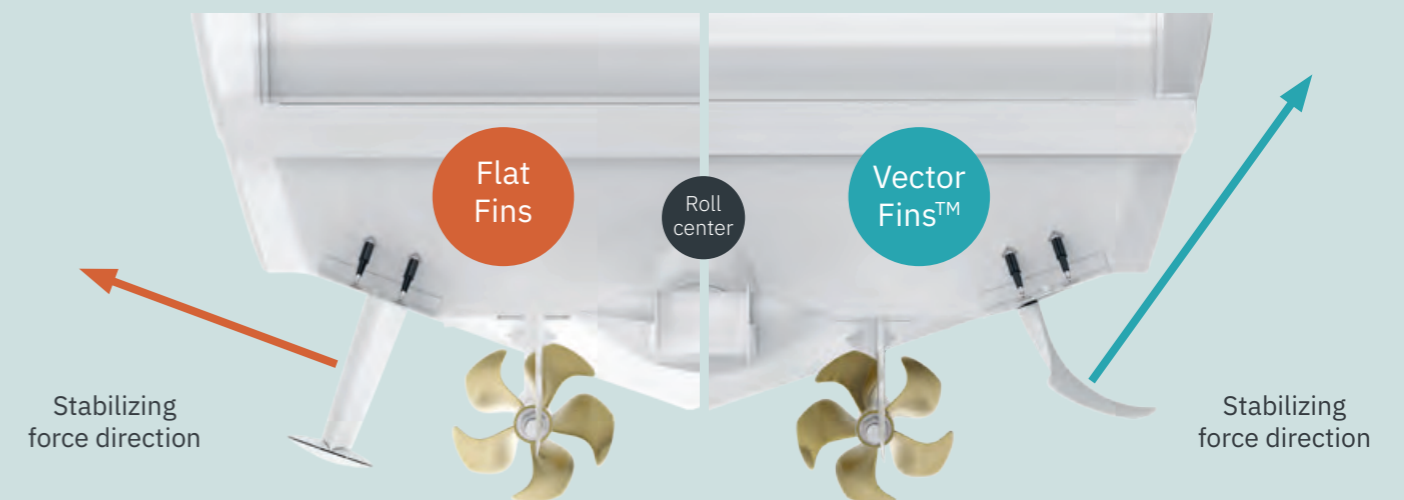

This simplified illustration shows how the Vector Fins™ better directs the fin forces toward the desired vertical direction, minimizing the energy waste of too many forces being used in the horizontal plane, which can cause unwanted side effects such as yaw and sway.



Sleipner electric actuators

The compact design of the actuator is cleverly engineered around a frameless torque motor and a Harmonic Drive strain wave gear. A combination of aluminum, composite, and stainless-steel materials for minimal weight and maximum life expectancy. The gear type is chosen considering the sometimes-extreme loads' fins get in heavy seas and have safety factors and features way above the gear types typically used in electric actuators.

Patented solution for noise cancellation

Another focus has been on noise reduction through its development, resulting in a patented solution reducing 92% of the structural born noise from the actuator.

Another benefit is that it reduces peak stress loads on both the gears and the hull.

Only premium brand name components

Integrated lifting points

The complete motor unit can easily be separated from the flange

Patented noise reduction

Easier installation with flange and bolt-lock ensuring a 100% connection

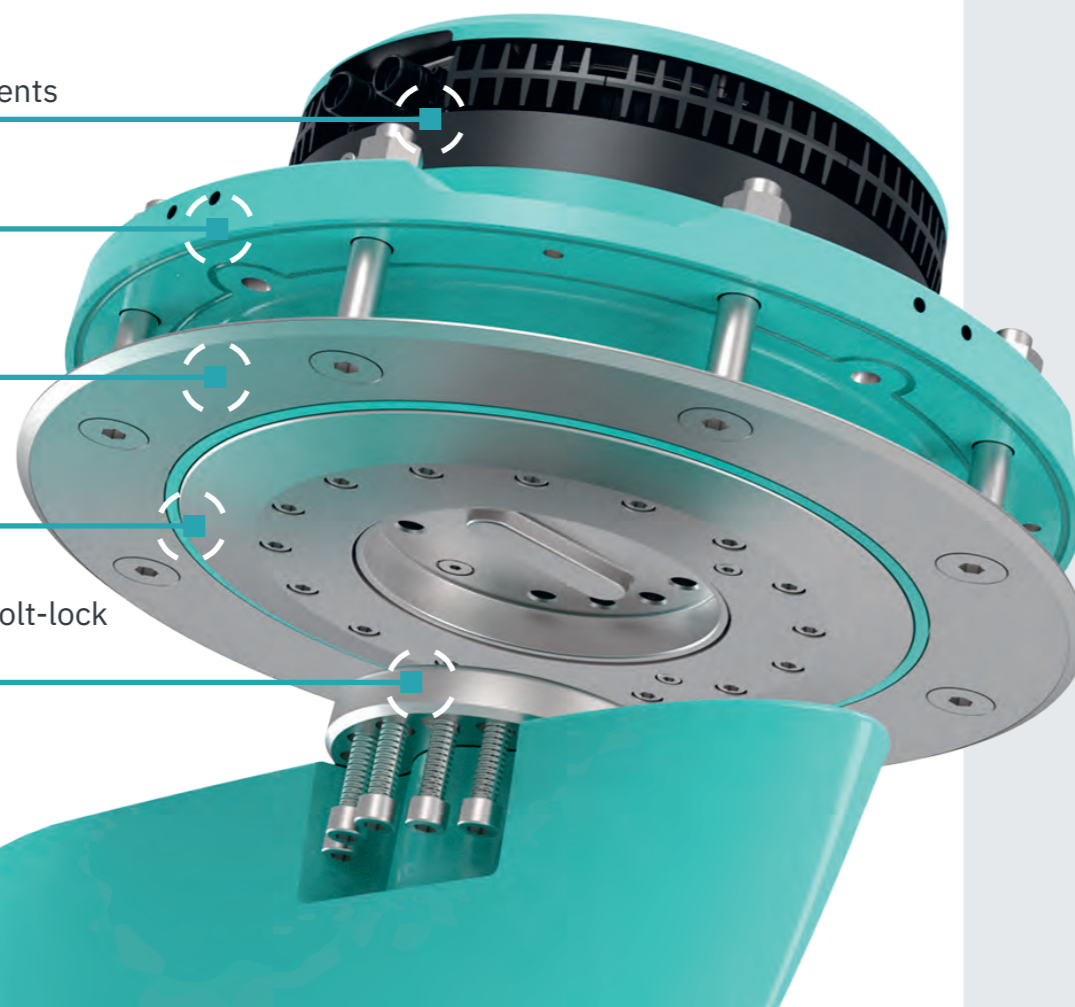

Key features actuator

- Instant on by the press of a button - no start-up period
- Light weight and compact construction
- Ultra responsive and energy efficient brush less motor
- Galvanically isolated design for easy installation in metal hulls
- 24/48V
- 230/400Volt – 1 and 3 phase

Serviceability

- Most parts can be changed on the water
- Motor unit can be removed from base flange in about an hours work
- Integrated lifting points
- Light weight aluminium construction

Stabilization panel and software

- Modern touch screen display prepared for flush installation
- Possibility for remote diagnostics and service through onboard Wi-Fi
- Rudder, gearbox and GPS input for more responsive stabilization
- Controls up to four fins for larger yachts
- Optional integration with MFD's (accessory)



Features

- Dock mode: turn the fin stroke angle more towards the keel when docking longside
- Eco mode: limit power consumption to extend operation time from the battery bank
- DP mode: Analyses gearbox, GPS, and compass heading when operating in Dynamic Position mode to avoid fin lock while reversing in low speed

Electric Vector Fins™

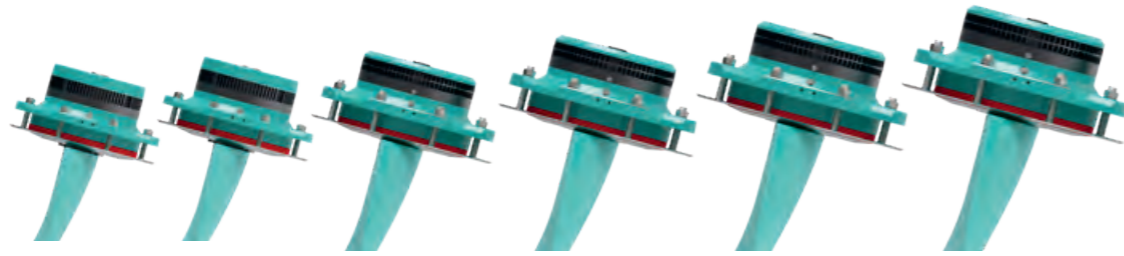

Technical data

Actuator type	SPS40E	SPS50E*	SPS60E	SPS70E*	SPS80E	SPS100E*
Power supply (VDC)	24/48	24/48	48	-	-	-
Power supply (VAC)	-	-	230(1Φ)/400(3Φ)	230(1Φ)/400(3Φ)	400(3Φ)	400(3Φ)
Typical boat size (ft)	45-60	55-70	65-80	75-100	95-125	120-150
Fin model up to 25 knots	V³700	V³900	V³1100	V³1400	V³1700	V³2200
Fin model 25+ knots	V³550	V³700	V³900	V³1100	V³1400	V³1700
Inside hull materials actuator	Aluminium housing					
Outside hull materials actuator	Composite and stainless steel					
Actuator weight (kg)	65	75	118	TBA*	296	TBA*

* Estimated launch in 2024 - please visit www.sleipnergroup.com or contact us for updated information

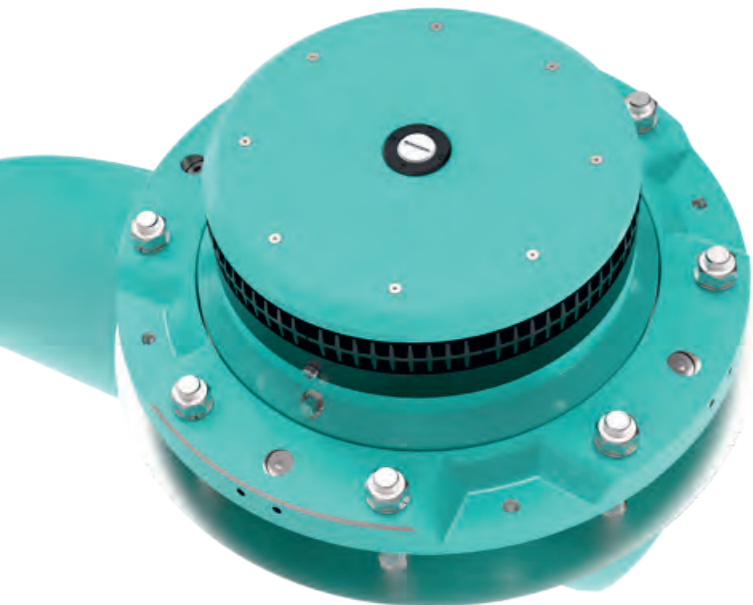

Main features

Any speed stabilizing	Yes
Dock mode	Yes
Eco mode	Yes
Dynamic Position mode	Yes
Patented noise reduction	Yes
Plug and play communication	Yes - S-link™
Thruster communication integration	Yes - S-link™
Galvanic isolated	Yes
4 fin configuration available	Yes
On water service	Yes
Industry leading efficiency	Yes

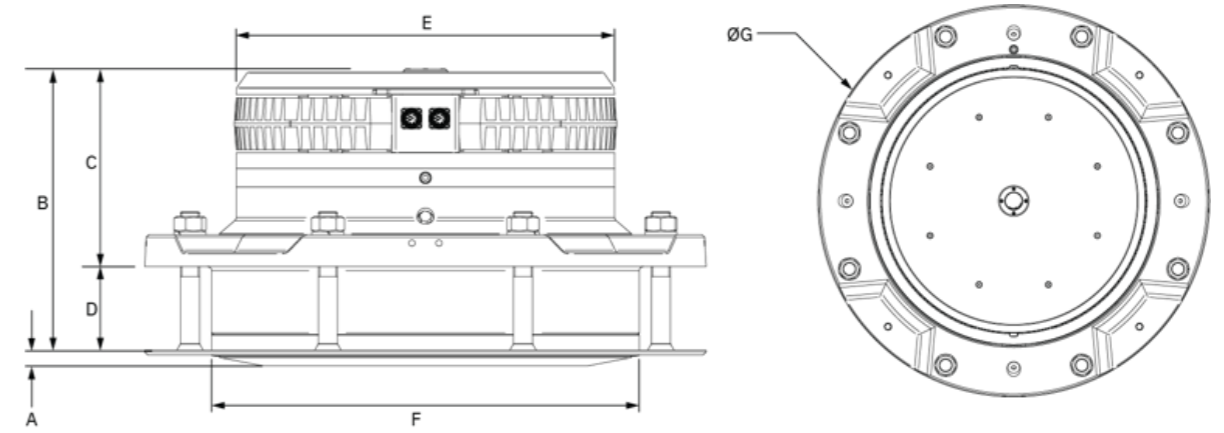

Measurements electric actuators

Code	Description	SPS40E	SPS50E*	SPS60E	SPS70E*	SPS80E	SPS100E*
A (mm)	Actuator height outside the hull	15.8	TBA*	16.8	TBA*	20	TBA*
B (mm)	Total actuator height	223	TBA*	236	TBA*	349	TBA*
C (mm)	Actuator height inside the hull	173	TBA*	172	TBA*	249	TBA*
D (mm)	Hull thickness (sealant included)	50	TBA*	60	TBA*	105	TBA*
ØE (mm)	Diameter of the actuator motor	290	310	350	TBA*	475	TBA*
ØF (mm)	Diameter of the actuator through the hull	340	360	408	TBA*	537	TBA*
ØG (mm)	Diameter of the actuator base	450	TBA*	540	TBA*	705	TBA*

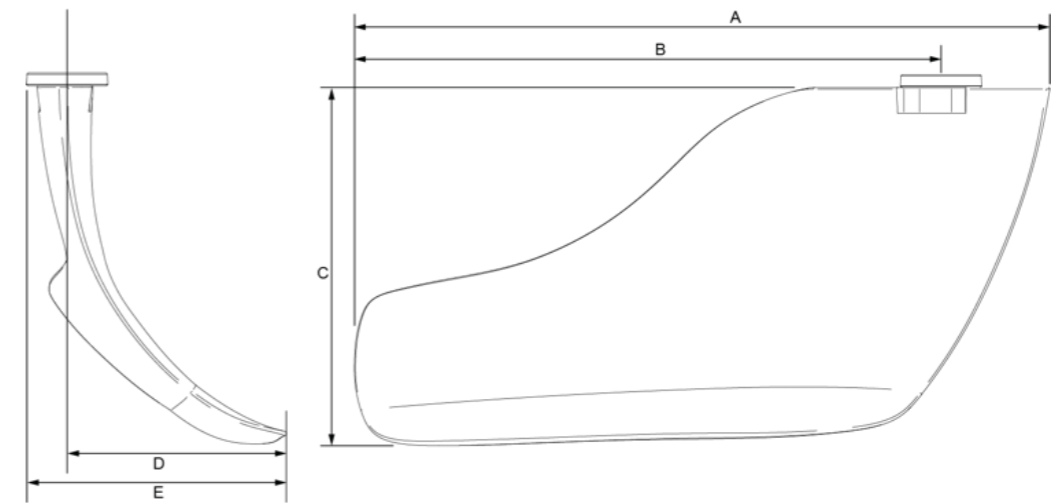

Measurements Vector Fins™

Code	Description	V³550*	V³700	V³900*	V³1100	V³1400*	V³1700	V³2200*
A (mm)	Total fin length	TBA*	1440	TBA*	1750	TBA*	2260	TBA*
B (mm)	Fin length to centre connection	TBA*	1220	TBA*	1490	TBA*	1920	TBA*
C (mm)	Total fin height	TBA*	690	TBA*	850	TBA*	1090	TBA*
D (mm)	Fin with from centre connection	TBA*	430	TBA*	520	TBA*	670	TBA*
E (mm)	Total fin width	TBA*	490	TBA*	600	TBA*	770	TBA*

* Estimated launch in 2024 - please visit www.sleipnergroup.com or contact us for updated information

SLEIPNER

World leading thruster systems

Built for outstanding performance, your time on the water will always be better with a Sleipner thruster onboard. With the world's most extensive thruster range, we can assure you will find the right fit for your boat.

Thruster finder Our models at a glance

How to choose the right thruster system

1. Thruster power

Whether you have decided to buy a bow or stern thruster, or planning to upgrade an existing installation, you will need to determine the amount of thrust output required to suit your specific need.

By definition, any thruster will, to some extent, get the job done. The key is to ensure that your chosen thruster will perform as expected in your boat specifically.

To choose the optimal solution for your boat, these are the main parameters you need to evaluate:

- Sufficient thrust to cover your intended use of the boat with a good safety margin
- Thruster placement on the boat
- Adequate and sustained energy supply

2. Available space for installation

Depending on the thruster size you need to achieve the required performance, the next step is to find the right thruster type based upon available space for installation.

In general, there are three thruster options based on their installation principle:

- Tunnel thrusters
- Retractable thrusters
- External thrusters

Tunnel thrusters are the standard fit for most boats. However, a retractable or external thruster are both great alternatives for vessels with insufficient internal space to fit the tunnel in the desired position.

3. Features

There are also optional features to consider. Perhaps the most important decision is whether you want a standard on/off-system or a PRO™ system with variable speed control, also often referred to as a proportional.

Main benefits of PRO™

- Unique hold-function enabling you to set and leave the level of thrust
- Single-handed docking
- Extended run time
- Less noise
- Joystick integration

Most Sleipner thruster models are available as PRO™ with variable speed control.

Other optional features to consider

- Ignition protection
- Cowls for stern thrusters to direct water flow
- Additional control panels for multiple control stations
- Remote controls
- Automatic main switch

4. Planning your system

When you have an idea about thruster size, type, and additional features of your choice, we recommend contacting a local Sleipner dealer. A professional installer will ensure an optimal and safe installation in your boat as well as guide you through a complete system setup of:

- Control panel(s)
- Remote control(s)
- Electrical installation and power optimization
- Tunnel and/or stern thruster choices
- Installation materials

Please visit sleipnergroupp.com to get in contact with your closest dealer.

Visit our website for in-depth information

Blog



How much thruster power do I need?

<https://www.sleipnergroupp.com/knowledge-hub/thrusters/how-much-power-do-i-need-from-a-boat-thruster>

Blog



How to choose the right thruster for your boat

<https://www.sleipnergroupp.com/knowledge-hub/thrusters/how-to-choose-the-right-thruster-for-your-boat>

Blog



Five benefits with variable speed control

<https://www.sleipnergroupp.com/knowledge-hub/thrusters/five-benefits-with-variable-speed-control>

Dealer



Find your closest dealer

<https://sleipnergroupp.com/support/map>

Blog



Do I need a bow thruster on a small boat?

<https://www.sleipnergroupp.com/knowledge-hub/thrusters/do-i-need-a-bow-thruster-on-a-small-boat>

Blog



Pros and cons of different thruster solutions

<https://www.sleipnergroupp.com/knowledge-hub/thrusters/pros-and-cons-of-different-thruster-solutions>

Watch



Magnus Rassy elaborates on PRO™ thrusters onboard a Hallberg Rassy 412

<https://www.youtube.com/watch?v=69GpzXrdpmw>

Blog



Breaking the stereotype: Boat thrusters aren't just for beginners!

<https://www.sleipnergroupp.com/knowledge-hub/thrusters/breaking-the-stereotype-boat-thrusters-aren-t-just-for-beginners>

Products



Explore bow and stern thrusters

https://sleipnergroupp.com/thruster-systems?IS_LEISURE=1/

CAD files



Thruster 3D files for professionals

Watch



User experience: PRO™ thrusters onboard a Bavaria Virtess 42 Fly

<https://www.youtube.com/watch?v=THtrKPa8ATI>

Thruster finder **Our models at a glance**

TUNNEL THRUSTERS

Sleipner's tunnel thrusters are the world's top-selling thrusters resulting from over 35 years of development. Over the years, our tunnel thrusters have been installed in more than 300,000 boats worldwide and are the preferred choice by most leading boat builders. With the world's largest selection of tunnel thrusters, there should be no compromise finding a good fit for your vessel.



DC electric



AC electric



Hydraulic

Ideal Vessel Class	Motor boat, Sail boat	Yacht, Commercial	Yacht, Commercial
Ideal Vessel Size	6–30 m / 20–100 ft	13–55 m / 42–175 ft	9–55 m / 30–175 ft
Power	DC 12/24/48V	AC	HYD
Thrust	20–340 kg	320–1400 kg	80–1400 kg
Tunnel diameter	110–300 mm	250–610 mm	185–610 mm
Placement	Bow / Stern	Bow / Stern	Bow / Stern
PRO™	Available	Yes	Available
Ignition Protection	Available	Yes	Yes
Learn more on page	46–49	58–61	62–67

EXTERNAL THRUSTERS

Sleipner's DC external thrusters are the most compact on the market, making it the perfect choice if you have a boat where the inside configuration does not fit a standard thruster installation. Its versatile design and compact size allow for installation on boats of any hull shape.



DC electric



DC electric



DC electric

Ideal Vessel Class	Motor boat, Sail boat	Motor boat	Motor boat, Sail boat
Ideal Vessel Size	6–11 m / 20–37 ft	10–17 m / 35–55 ft	6–18 m / 20–59 ft
Power source	DC 12V	DC 12 / 24V	DC 12/24V
Thrust	42–62 kg	96–116 kg	42–116 kg
Tunnel diameter	140 mm	185 mm	150 mm
Placement	Bow / Stern	Stern	Bow / Stern
PRO™	Available	Yes	No
Ignition Protection	Yes	Yes	Yes
Learn more on page	78	79	80–81

RETRACTABLE THRUSTERS

For cruisers or flat-bottomed boats. Our retractable thrusters are designed with a focus on practical sturdiness, uncompromised safety, and quick deployment. Also suitable as stern thrusters on motorboats that cannot fit a tunnel or external stern thruster on the transom.



DC electric



AC electric



Hydraulic

Ideal Vessel Class	Motor boat, Sail boat	Motor boat, Sail boat	Motor boat, Sail boat
Ideal Vessel Size	10–30m / 35–98ft	22–34m / 72–110ft	13–46m / 42–150ft
Power	DC 12/24/48V	AC	HYD
Thrust	80–340kg	320kg	240–320kg
Tunnel diameter	185–300 mm	300 mm	250–386 mm
Placement	Bow / Stern	Bow / Stern	Bow / Stern
PRO™	Available	Available	Available
Ignition Protection	Available	Yes	Yes
Learn more on page	68–74	68–74	68–74

Blog



Pros and cons of different thruster solutions

<https://www.sleipnergrou.com/knowledge-hub/thrusters/pros-and-cons-of-different-thruster-solutions>



Main thruster features



GALVANIC SEPARATION

Immersed parts exposed to seawater are galvanic isolated from the onboard electrical system, eliminating stray currents.



OVERHEAT PROTECTION

Automatic detection of overheating of internal components. When an unsafe temperature is detected, the unit is automatically shut off to prevent overheating.



SAFE STARTUP

Sleipner control panels use dual 'ON' buttons to engage the product to start to prevent accidental activation for a child-safe environment.



GRAVITY FEED LUBRICATION

The thruster gearleg is supplied with oil from a separate reservoir above the waterline. This generates overpressure, making an effective seal against water intrusion while allowing easy access for oil change.



PRO™ VARIABLE SPEED CONTROL

A PRO™ thruster system enables you to apply only the necessary power to complete your maneuver. The variable speed control eliminates the noise associated with standard on/off thrusters.

The system also includes a practical hold-function. In a dual system (bow and stern) a single press of a button will keep you alongside the docks - making docking truly a one-person job.

Speed controlled thrusters are the best choice for joystick interaction.



SEALED DRIVE LUBRICATION

The thruster gearleg is pre-filled for lifetime lubrication and sealed using a long-time mechanical seal with ceramic and carbon surfaces for ultimate security against water intrusion.



IGNITION PROTECTION

Our ignition-protected products are compliant with ISO 8846 and ensure gasoline or other flammable fumes cannot enter or be ignited.



Q-PROP

The Q-PROP™ has measured noise reductions of up to 75% in controlled environments. The five-bladed skew propeller reduces noise levels while maintaining exceptional efficiency. Some thruster models even see an increase in thrust power.

The expected noise reduction in average installations: 20-40%.

Upgrade kits are available for most Sleipner thruster models with special adaptors.



S-LINK™

S-Link™ is a CAN-based control system used for communication between Sleipner products installed on a vessel.

- Compact and waterproof plugs
- Keyed and color-coded connectors to ensure correct and easy installation
- Different cable lengths, extenders and T-connectors makes the system scalable and flexible to install.



INTELLIGENT POWER CONTROL

Sleipner's patented intelligent power control provides a minimal delay between drive directions to reduce wear of the mechanical parts while monitoring solenoid functions. In the case of a solenoid lock-in, the thruster will automatically stop without extra user action or controlling the main switch.



SMART SHUT-OFF

Sleipner control panels are programmed to shut down automatically after approximately 6 minutes without use to avoid accidental activation.

Please visit sleipnergroupp.com for complete technical information and an overview of features per product.

Standard on-off versus variable speed control

Dock smooth and quietly with speed controlled thrusters

Put a throttle in your thruster!

Get the luxury of silently adjusting how much thrust to use when maneuvering your boat into our out of a tight spot using variable speed control. Combining known performance and reliability with total control of thruster power provides an ease to beginners as well as seasoned boaters, while eliminating much of the noise associated with on-off thrusters.

Increasing boat sizes and the number of boats have outrun the harbor space for many years around the globe, making docking more challenging than ever. Easy maneuvering has become more critical, making thrusters a standard fit in most boats, as they undeniably offer great help while docking in challenging locations or adverse weather conditions.

With many boat owners having had boats with under-powered thrusters, they now would like to have enough power in their thrusters to make sure they perform well and do their job in the worst conditions. To install a thruster system rated for the worst conditions is advisable, as it is in these situations you need a thruster system the most.

However, while docking in calm weather conditions, many boat owners find that using 100% of the thruster effect is unnecessary and creates unwanted noise in an otherwise quiet harbor.

Sleipner PRO (proportional) thrusters will be a different experience and provide a no-compromise solution with fully speed-controlled thrusters. Unlike on-off thruster systems, where you will get a 100% thrust at once, a proportionally controlled system starts at a lower RPM as you throttle on. This makes a massive difference as the softer acceleration

creates a lot less cavitation in the tunnel, which reduces noise in a thruster.

As you can now choose the right thrust for any docking situation, docking in a quiet harbor does not need a lot of power, and you will find that you can slip the boat into your dock almost without making a sound.

When running the thruster at reduced power, the heat development in a DC electric motor is much lower. In most cases, at 50% power or less, you can expect close to continuous run time, only limited by your available power supply.

The first part of docking is maneuvering alongside the pier safe and smoothly. The second part is staying there until you are tied off. With a twin system with variable speed control (bow and stern thruster), you also get a practical hold-function, enabling you to set and leave the level of thrust. It's a feature that short-handed skippers often rely on to pin their boats against the dock while they step off to secure the lines. You can easily adjust the amount of thrust applied depending on the docking conditions.

Visit www.sleipnergroup.com to learn more.

Main features:

- Full proportional speed control
- Unique hold-function
- Single-handed docking
- Best choice for joystick interaction
- Wide range of PRO thrusters
- Extended runtime
- Less noise

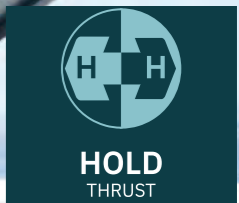

Most thruster systems can be upgraded with several practical benefits.

Available thruster upgrades

Improve the performance of your existing thruster system

The fact that Sleipner delivers spare parts such as zinc anodes and shear pins to 30-year-old thrusters is a statement of our commitment to our products' quality and longevity, past and present. There are several upgrades to consider to an existing thruster system adding practical value for years to come.

Upgrade to PRO variable speed control

Most Sleipner (Side-Power) DC 12 and 24V models from 1999/2000 and later can be updated to PRO with variable speed control.

Scan the QR code to see products and videos about upgrading.



Add a remote control

Free yourself from the dashboard. You can operate the system remotely for easy short-handed docking by adding a remote control.

Scan the QR code to go directly to products.



Upgrade your propeller

The Sleipner Q-propeller typically reduces noise between 20-40% in average installations, while maintaining or slightly increasing thrust output.

Scan the QR code to check if your thruster can be upgraded.

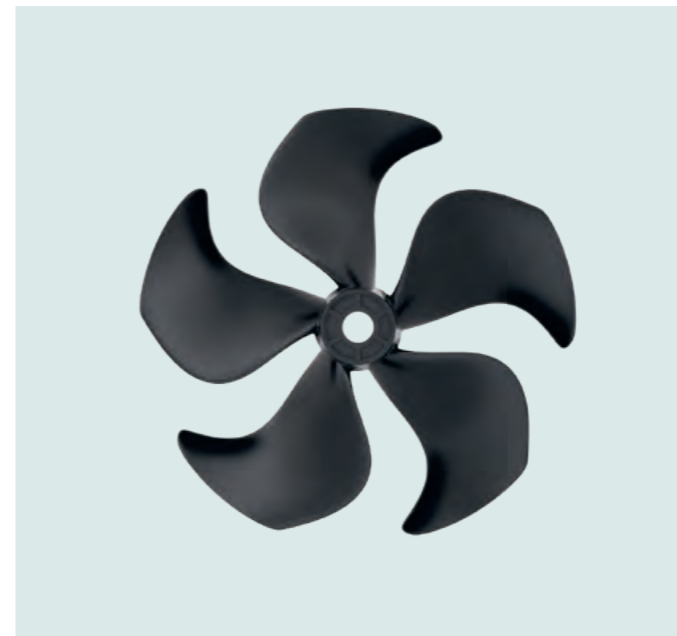

Add a stern thruster

The selection of stern thrusters has increased significantly, allowing space-saving solutions for additional vessel types.

Scan the QR code to see our complete stern thruster program.



Motor upgrade to E-series

Previous Sleipner thruster models can be upgraded with E-series motors if needed. Some models will fit directly on to the old motor brackets and some models will need an adapter plate and/or an upgraded flexible coupling. Contact your local dealer for more information.



E-series electric tunnel thrusters

Our new top of the line thruster series incorporates a highly efficient, compact, and lightweight electric motor made explicitly for marine thruster use.

When combining our new, state-of-the-art electric motor with the proven Sleipner gearleg design and Q-Prop™ skew propeller, you get a thruster that delivers performance and runtime never seen before in a DC thruster. The result is the new E-series of thrusters.

The E-series comes with the proven quality and performance of Sleipner's gearleg and propeller design. Sleipner has optimized their design through more than 300.000 thrusters delivered over the last 40 years.

Previous Sleipner thruster models can be upgraded with the new E-series electric motor either directly or by utilizing an adapter plate between the bracket and motor.

Benefits

- Up to 50 percent lighter and smaller motor
- Ignition protected
- Integrated inverter for variable speed control
- Industry-leading runtimes
- Less noise
- More compact
- Splashproof
- Retrofit options
- Made in Norway



With stern thruster kit

Product features

- ✕ IGNITION PROTECTION
- Ⓢ S-LINK™
- ⊙ SEALED DRIVE LUBRICATION
- ⚙️ Q-PROP™
- ⚡ GALVANIC SEPARATION
- 🔊 PRO™

Technical details

Ideal Vessel Class	Motor boat, Sail boat
Ideal Vessel Size	10–30 m / 35–100 ft
Power	DC 24/48V
Thrust	25–340 kg / 55–749 lbs
Tunnel diameter	110–300 mm
Placement	Bow / Stern



E-series tunnel thrusters	E100/185T	E120/215T	E130/250T	E150/215T	E170/250TC	E210/250TC
	24V/48V	24V/48V	24V/48V	24V/48V	24V/48V	24V/48V
Thrust at 24/48V (kg)	100	120	130	150	170	210
Thrust at 21/42V (kg)	100	120	130	150	170	210
Ideal Vessel Size (m/ft)	12-17/35-55	14-20/44-64	13-19/42-63	14-20/44-64	15-22/50-70	17-24/55-78
Internal Diameter (mm)	185	215	250	215	250	250
Propulsion System	Twin	Twin	Twin	Twin	Twin Counter	Twin Counter
Power Output (kW • Hp)	5.6 • 7.6	6.0 • 8.0	5.1 • 6.8	8.1 • 10.9	7.3 • 9.9	10.4 • 14.0
Power requirement (V)	24/48	24/48	24/48	24/48	24/48	24/48
Weight (kg)	25	27	29	27	30	37
Min. Battery CCA (DIN)	290/130	330/170	270/160	430/210	395/200	580/290
Item Code 24V	E100/185T-24V	E120/215T-24V	E130/250T-24V	E150/215T-24V	E170/250TC-24V	E210/250TC-24V
Item Code 48V	E100/185T-48V	E120/215T-48V	E130/250T-48V	E150/215T-48V	E170/250TC-48V	E210/250TC-48V

E240/250TC	E250/300TC	E300/300TC
48V	24V/48V	48V
240	250	300
240	250	300
17-24/55-78	22-30/72-100	22-30/72-100
250	300	300
Twin Counter	Twin Counter	Twin Counter
12.7 • 17.0	11.1 • 14.9	15 • 20
48	24/48	48
37	43	43
330	585/295	360
	E250/300TC-24V	
E240/250TC-48V	E250/300TC-48V	E300/300TC-48V

Stern tunnel kit	90086i	90135i	90150i	90135i	90150i	90150i
Cowls - short model	90075	—	—	—	—	—
Cowls - long model	90077	90136	90130	90136	90130	90130

90150i	90200i	90200i
90130	90220	90220

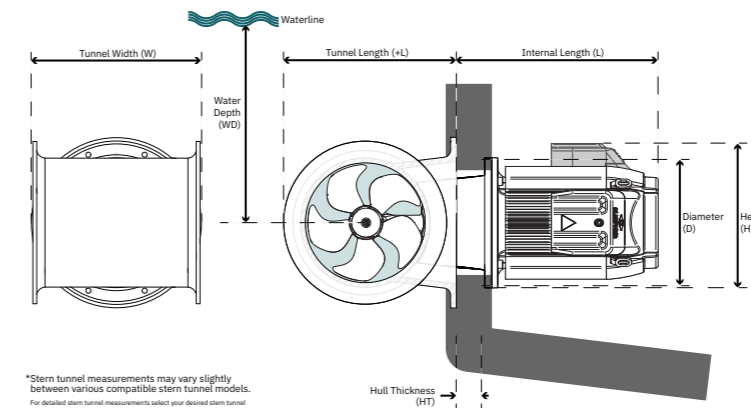
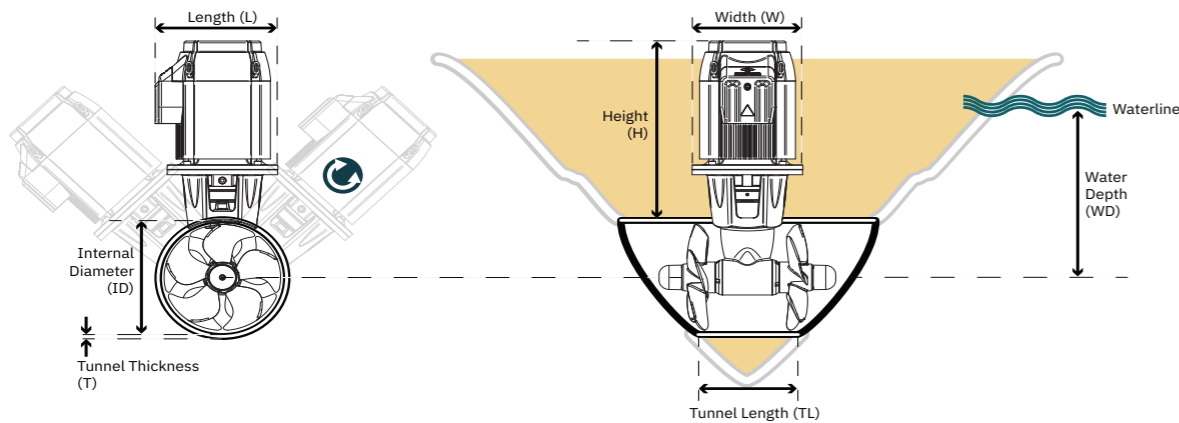

*Stern tunnel measurements may vary slightly between various compatible stern tunnel models. For detailed stern tunnel measurements select your desired stern tunnel model from the compatible products tab.

Bow	Description
(H)	Height
(L)	Length
(W)	Width
(ID)	Internal Diameter
(WD)	Water Depth
(TL)	Recommended Tunnel Length
(TL min.)	Minimum Tunnel Length
(T min.)	Minimum Tunnel Wall Thickness
(T max.)	Maximum Tunnel Wall Thickness
Stern	
(L)	Internal Length
(+L)	Tunnel Length
(WD)	Stern Water Depth
(HT)	Maximum Hull Thickness

Sleipner thrusters can be installed at an angle off the vertical centre. Tailored to fit any space available in your vessel.

BOW	E100/185T	E120/215T	E130/250T	E150/215T	E170/250TC	E210/250TC	E240/250TC	E250/300TC	E300/300TC
	24/48V	24/48V	24/48V	24/48V	24/48V	24/48V	48V	24/48V	48V
H (mm)	401	387	387	387	387	427	427	437	437
L (mm)	285	285	285	285	285	285	285	285	285
W (mm)	258	258	258	258	258	258	258	258	258
ID (mm)	185	215	250	215	250	250	250	300	300
WD (mm)	185	215	250	215	250	250	250	300	300
TL (mm)	216	280	323	280	322	323	323	340	340
TL min. (mm)	179	235	273	235	272	273	273	280	280
T min. (mm)	6	6	7	6	7	7	7	10	10
T max. (mm)	8	8	9	8	9	9	9	12	12

STERN	E100/185T	E120/215T	E130/250T	E150/215T	E170/250TC	E210/250TC	E240/250TC	E250/300TC	E300/300TC
	24/48V	24/48V	24/48V	24/48V	24/48V	24/48V	48V	24/48V	48V
L (mm)	359	354,5	339	354,5	339	370	370	387	387
+L (mm)	265	300	345	300	344,5	353	353	419	419
WD (mm)	185	215	250	215	250	250	250	300	300
HT (mm)	42	57	42	57	42	33	33	50	50

DC electric tunnel thrusters

Sleipner's tunnel thrusters are the world's top-selling bow and stern thrusters for recreational boats. Over the years, our tunnel thrusters have been installed in more than 300,000 boats worldwide.

The bow and stern thrusters are fitted either in a tunnel through the boat's bow or into a stern tunnel at the boat's stern.

The electric motors, solenoid, patented IPC control system, and mechanical parts of the propulsion system are all custom designed and built - utilizing the extensive experience gained through years of leadership in the global thruster market.

Sleipner's stern tunnels are designed with solid and durable fiberglass to enhance the thruster's performance and are mounted effortlessly in the boat's transom.

Benefits

- Proven performance
- Low noise
- Flexible installation/mounting
- High-quality components
- Overheat protection
- Low maintenance
- Intelligent Power Control

Also available in PRO versions with variable speed control

Product features

- INTELLIGENT POWER CONTROL
- SEALED DRIVE LUBRICATION
- GALVANIC SEPARATION
- Q-PROP™

Technical details

Ideal Vessel Class	Motor boat, Sail boat
Ideal Vessel Size	6–30 m / 20–100 ft
Power	DC 12/24/48V
Thrust	25–340 kg / 55–749 lbs
Tunnel diameter	110–300 mm
Placement	Bow / Stern



	SE20	SE25	SE30 ¹	SE40 ¹	SE50	SE60	SE80	SE100
	12V	12V	12V	12V	12V 24V	12V 24V	12V 24V	12V 24V
Thrust at 12/24V (kg)	25	30	40	48	62 62	73 73	96 96	116 116
Thrust at 10.5/21V (kg)	20	25	30	40	50 50	60 60	80 80	100 100
Ideal Vessel Size (m/ft)	>7/23	>7/24	6-8/20-28	8-10.5/26-34	8-11/27-37	8-11/27-37	10-15/35-48	12-17/35-55
Internal Diameter (mm)	110	110	125	125	140 140	185 185	185 185	185 185
Propulsion System	Single	Single	Single	Single	Single Single	Single Single	Twin Twin	Twin Twin
Power Output (kW • Hp)	1.5 • 2	1.5 • 2	1.5 • 2	2.2 • 3	2.4 • 3.2 2.4 • 3.2	3.1 • 4.0 2.4 • 3.2	4.4 • 6 4.4 • 6	6.3 • 8.4 6.3 • 8.4
Power requirement (V)	12	12	12	12	12 24	12 24	12 24	12 24
Weight (kg)	9.5	9.5	9.5	10	15 15	15 15	20 20	31 31
Min. Battery CCA (DIN)	200	200	200	300	350 175	350 175	550 300	750 400
Item Code 12V	SE20/110S	SE25/110S	SE30/125S2	SE40/125S2	SE50/140S-12V	SE60/185S2-12V	SE80/185T-12V	SE100/185T-12V
Item Code 24V					SE50/140S-24V	SE60/185S2-24V	SE80/185T-24V	SE100/185T-24V
Item Code 12V PRO	SEP20/110S	SEP25/110S	SEP30/125S2	SEP40/125S2	SEP50/140S-12V	SEP60/185S2-12V	SEP80/185T-12V	SEP100/185T-12V
Item Code 24V PRO					SEP50/140S-24V	SEP60/185S2-24V	SEP80/185T-24V	SEP100/185T-24V
Stern tunnel kit	—	—	90124i	90124i	—	90052i	90086i	90086i
Cowls - short model	—	—	—	—	—	90075	90075	90075
Cowls - long model	—	—	90126	90126	—	90077	90077	90077



SE120/215T	SE130/250T	SE150/215T	SE170/250TC	SE210/250TC	SE250/300TC	SE300/300TC
24V	12V 24V	24V	24V	24V	24V	48V
139	160 160	182	210	250	300	340
120	130 130	150	170	210	250	300
13-18/42-60	13-19/42-62	14-20/44-64	15-22/50-70	17-24/55-78	18-25/60-84	22-30/72-100
215	250 250	215	250	250	300	300
Twin	Twin Twin	Twin	Twin Counter	Twin Counter	Twin Counter	Twin Counter
6.4 • 8.55	6.5 • 8.7 6.5 • 8.7	8.8 • 11.8	8.8 • 11.8	10 • 13.15	11.4 • 15.5	15 • 20
24	12 24	24	24	24	24	48
34	37 37	38	44	68	70	73
450	750 400	560	560	560	700	400
SE120/215T	SE130/250T-12V					
SE120/215T	SEP130/250T-12V					
SEP120/215T						
90135i	90150i	90135i	90150i	90150i	90200i	90200i
—	—	—	—	—	—	—
90136	90130	90136	90130	90130	90220	90220

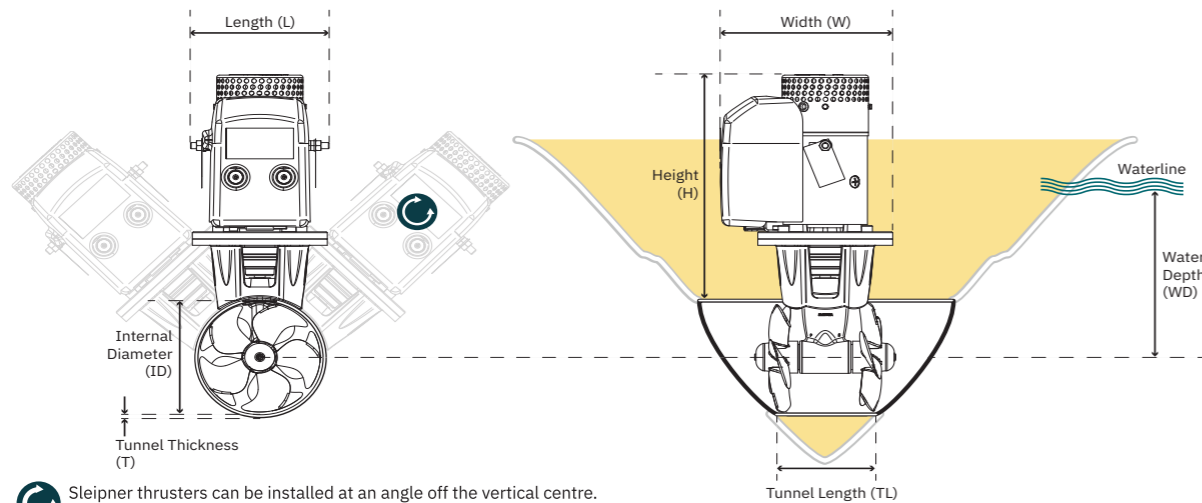

Sleipner thrusters can be installed at an angle off the vertical centre. Tailored to fit any space available in your vessel.

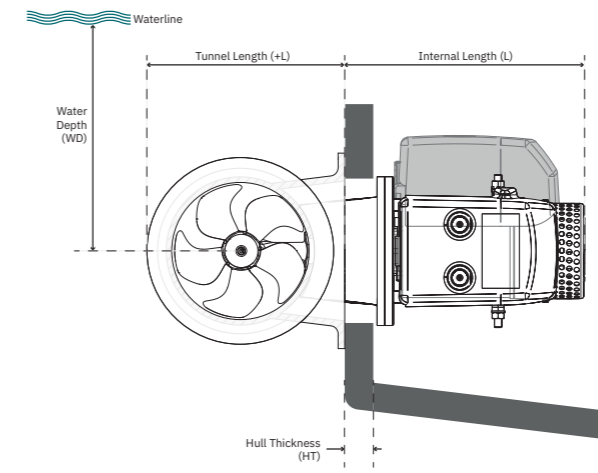

Bow	Description
(H)	Height
(L)	Length
(W)	Width
(ID)	Internal Diameter
(WD)	Water Depth
(TL)	Recommended Tunnel Length
(TL min.)	Minimum Tunnel Length
(T min.)	Minimum Tunnel Wall Thickness
(T max.)	Maximum Tunnel Wall Thickness
Stern	Description
(L)	Internal Length
(+L)	Tunnel Length
(WD)	Stern Water Depth
(HT)	Maximum Hull Thickness

BOW	SE20	SE25	SE30 ¹	SE30 ¹	SE40 ¹	SE40 ¹	SE50	SE60	SE80	SE100	SE120	SE130	SE150	SE170	SE210	SE250	SE300	
	12V	12V	12V	12V	12V	12/24V	12/24V	12/24V	12/24V	12/24V	24V	12V 24V	24V 24V	24V 24V	24V 24V	24V 24V	24V 24V	
H (mm)	209	252	263	242	263	242	264	272/264	352/344	393	394	398	398	412	412	480	490	457
L (mm)	183	183	183	186	183	183	208	208	206	240	243	250	250	245	247	274	274	274
W (mm)	200	198	199	198	206	205	200	200	252/261	292/272	266	296	277	292	292	337	337	350
ID (mm)	110	110	125	140	125	140	140	140	185	185	215	250	250	215	250	250	300	300
WD (mm)	110	110	125	140	125	140	140	185	185	185	215	250	250	215	250	250	300	300
TL (mm)	133	133	136	168	136	168	152	152	216	216	276	303	303	276	322	323	333	333
TL min. (mm)	111	111	111	140	111	140	124	124	179	179	233	253	253	233	272	273	273	273
T min. (mm)	4	4	4	5.2	4	5.2	5	5	6	6	7	7	7	7	7	10	10	10
T max. (mm)	6	6	6	7	6	7	7	7	8	8	9	9	9	9	9	12	12	12

STERN	SE20 ³	SE25 ³	SE30 ²	SE30 ²	SE40 ²	SE40 ²	SE50 ³	SE60	SE80	SE100	SE120	SE130	SE150	SE170	SE210	SE250	SE300
	12V	12V	12V	12V	12V	12V	12/24V	12/24V	12/24V	12/24V	24V	12/24V	24V	24V	24V	24V	24V
L (mm)	-	-	218	-	228	-	-	231/ 214	294/303	351	361	352/ 348	380	362	422	440	407.2
+L (mm)	-	-	188	-	188	-	-	265	265	265	300	345	300	345	360	417	422
WD (mm)	-	-	125	-	125	-	-	185	185	185	215	250	215	250	250	300	300
HT (mm)	-	-	19	-	17	-	-	43	56	60/64	61	56/55	73	56	50	68	67

Please see note regarding thruster power and battery rating on page 114.
¹ SE30 and SE40 bow thruster are available in both 125 mm and 140 mm tunnel / 125S2 = 125 mm tunnel / 140S = 140 mm tunnel.
² SE30 and SE40 stern thruster are available in 125 mm tunnel only
³ SE20, SE25 and SE50 are not available as stern thruster

Also available in PRO versions with variable speed control

Ignition Protected DC electric tunnel thrusters

Benefits

- Tested according to ISO 8846 Ignition Protected standards
- Splash proof housing
- Tinned plated brass terminals
- Manufactured, tested and delivered as a ready sealed unit, ensuring that the installer does not have to fit any other parts that can jeopardize the hermetical seal
- Plug & Play control cables
- Accessible components and easy maintenance
- Flexible installation/mounting

Sleipner offers modified versions of our DC electric thrusters to provide reliable and safe thruster installations. The IP version (ignition protected) have a hermetically sealed composite housing around all electric parts. The IP versions are for use in stern and other locations that may get wet or be exposed to gasoline fumes.

An additional advantage is that electric parts that could obtain water damage are also covered and protected, making these thrusters the ideal choice for stern thruster installations where ensuring that the thruster will always remain dry is difficult.

The IP versions have all the benefits and proven reliability of our standard DC electric tunnel thrusters.

Product features

- ✕ IGNITION PROTECTION
- i INTELLIGENT POWER CONTROL
- 🔥 SEALED DRIVE LUBRICATION
- ⚡ GALVANIC SEPARATION
- 🌀 Q-PROP™

Technical details

Ideal Vessel Class	Motor boat, Sail boat
Ideal Vessel Size	6–17m / 20–55ft
Power	DC 12/24V
Thrust	40–100kg / 88–220lbs
Tunnel diameter	125–185 mm
Placement	Bow / Stern



	SE30 IP	SE40 IP	SE50 IP	SE60 IP
Thrust at 12/24V (kg)	40	48	62	73
Thrust at 10.5/21V (kg)	30	40	50	60
Ideal Vessel Size (m/ft)	6-8/20-28'	8-10.5/26-34'	8-11/27-37'	9-12/29-38'
Internal Diameter (mm)	125	125	140	185
Propulsion System	Single	Single	Single	Single
Power Output (kW • Hp)	1.5 • 2	2.2 • 3	2.4 • 3.2	2.4 • 3.2
Power requirement (V)	12	12	12/ 24	12/ 24
Weight (kg)	9.5	10	15	16
Min. Battery CCA* (DIN)	200	300	350	350

Item Code 12V	SE30/125S2-12IP	SE40/125S2-12IP	SE50/140S-12IP	SE60/185S2-12IP
Item Code 24V			SE50/140S-24IP	SE60/185S2-24IP
Item Code 12V PRO	SEP30/125S2-12IP	SEP40/125S2-12IP	SEP50/140S-12IP	SEP60/185S2-12IP
Item Code 24V PRO			SEP50/140S-24IP	
Stern tunnel kit	90124i	90124i	—	90052i
Cowls - short model	—	—	—	90075
Cowls - long model	90126	90126	—	90077



SE80 IP	SE100 IP
96	116
80	100
10-15/35-48'	12-17/35-55'
185	185
Twin	Twin
4.4 • 6	6.3 • 8.4
12/ 24	12/ 24
20	31
550	750

SE80/185T-12IP	SE100/185T-12IP
SE80/185T-24IP	SE100/185T-24IP
SEP80/185T-12IP	SEP100/185T-12IP
SEP80/185T-24IP	SEP100/185T-24IP
90086i	90086i
90075	90075
90077	90077

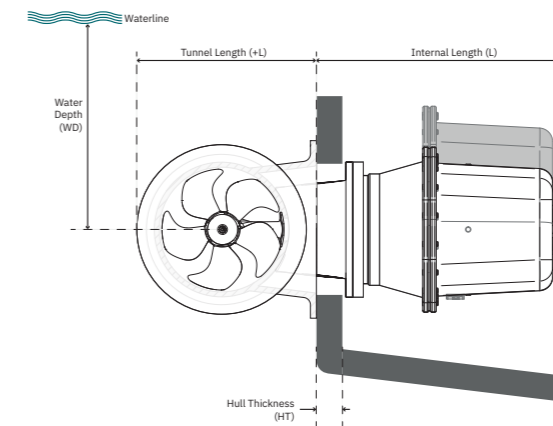
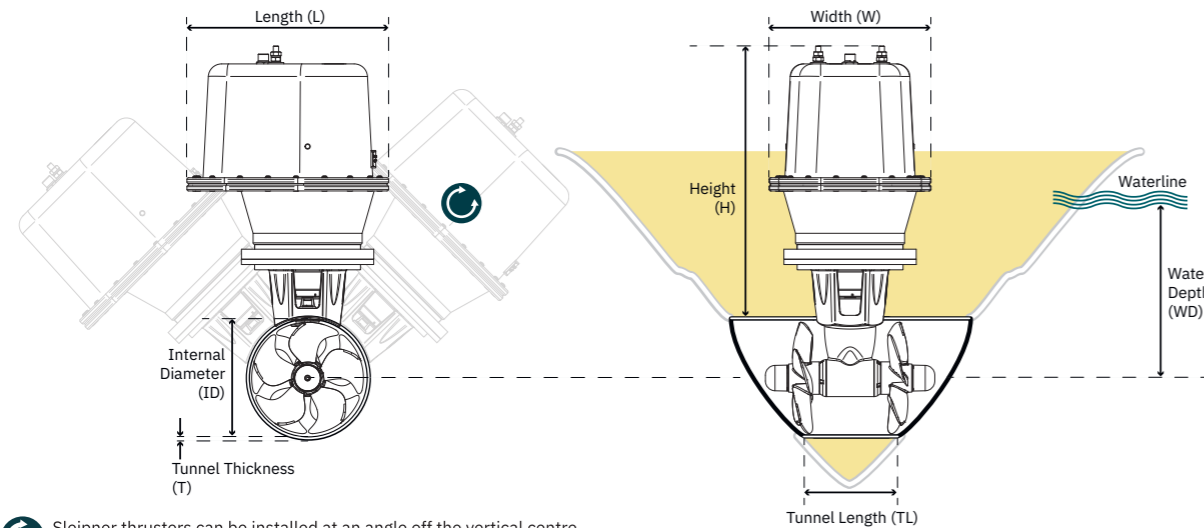

Sleipner thrusters can be installed at an angle off the vertical centre. Tailored to fit any space available in your vessel.

BOW	SE30 IP	SE40 IP	SE50 IP	SE60 IP	SE80 IP	SE100 IP
	12V	12V	12V/24V	12/24V	12/24V	12/24V
(H) Height (mm)	291	288	323	321	406	499/ 510
(L) Length (mm)	238	238	272	272	327	381
(W) Width (mm)	234	234	232	232	262	306
(ID) Internal Diameter (mm)	125	125	140	185	185	185
(WD) Water Depth (mm)	125	125	140	185	185	185
(TL) Recommended Tunnel Length (mm)	136	136	152	165	216	195/ 216
(TL min.) Minimum Tunnel Length (mm)	111	111	124	128	179	158
(T min.) Min. Tunnel Wall Thickness (mm)	4	4	5	4	6	6
(T max.) Max. Tunnel Wall Thickness (mm)	6	6	7	6	8	8

STERN	SE30 IP	SE40 IP	SE50 IP	SE60 IP	SE80 IP	SE100 IP
	12V	12V	12V	24V	12/24V	12/24V
(L) Internal Length	256	268	-	-	278	364
(+L) Tunnel Length	188	188	-	-	265	265
(WD) Stern Water Depth	125	125	-	-	185	185
(HT) Maximum Hull Thickness	70	65	-	-	88	64

Please see note regarding thruster power and battery rating on page 114.

AC electric tunnel thrusters

Sleipner's AC thrusters offer the benefit of unlimited run time, enabling heavier duty usage. Each system is custom-built according to your boat's specifications and working conditions. AC thrusters are also perfect for hybrid or fully electric vessels.

Sleipner's AC thruster systems are precisely matched to the generator capacity to maximize the amount of thrust you get from the system.

Each AC motor is controlled via a Variable Frequency Drive (VFD) to minimize startup loads on the power system and allow for precise control of the thruster with variable speed control. No further setup of the VFD is required. The PDC-301 drive controller is configured from the control panel.

In addition to the standard VFD's, we can deliver low harmonic VFD's for installations with specific THD requirements.

An Electromagnetic Compatibility filter (EMC) is also included to reduce feedback noise on the vessel's power system.

The innovative S-Link™ control system ensures fast and trouble-free installation, and gives you the unique option to combine hydraulic and AC thrusters in a single control environment.

All of Sleipner's AC systems can be mixed and matched with hydraulic and DC Electric PRO systems with seamless integration.

All AC components are selected from top brand manufacturers ensuring the best quality and worldwide support. Standard range is designed for 230V / 400V 3-phase. Setup for alternative power supply specifications can be delivered on request.

Benefits

- Continuous use
- Controlled power
- Reliability
- S-Link™ operating system
- Custom-made, ready to install with Plug & Play wiring
- The choice of leading boatbuilders
- DNV type approval for specific models
- Cost efficient, high quality components
- Suitable for joystick and DP integration



Specific models



- Complete AC thruster kit including
- PDC 301 drive controller
 - Variable Frequency Drive (VFD)
 - Gearleg with propellers and bracket
 - Flexible coupling
 - AC motor
 - EMC filter

Product features

- S-LINK™
- SEALED DRIVE LUBRICATION
- GRAVITY FEED
- Q-PROP™
- GALVANIC SEPARATION (OPTIONAL)
- PRO™

Technical details

Ideal Vessel Class	Motor boat, Sail boat
Ideal Vessel Size	13–55 m / 42–175 ft
Power	AC 230/400V
Thrust cont.	240–1200 kg/529–2646 lbs
Thrust max.	240–1400 kg/529–3086 lbs
Tunnel diameter	250–610 mm
Placement	Bow / Stern

Image courtesy of Sunseeker Inc.



For leisure usage

	SAC240/250TC	SAC320/300TC	SAC360/300TC	SAC450/386TC	SAC520/386TC	SAC520/386TC
Continuous Thrust (kg)	240	280	360	450	520	520
Thrust, max. (kg) ¹	-	320	-	-	520	-
Power Output (kW • Hp)	14 • 19	21 • 27	27 • 37	28 • 38	35 • 48	35 • 48
Ideal Vessel Size (m/ft)	13-23/42-75	17-31/55-100	18-33/59-108	22-35/75-110	25-40/85-140	25-40/85-140
Internal Diameter (mm)	250	300	300	386	386	386
Item Code	SAC240/250-C-x-x	SAC320/300-I-x-x	SAC360/300-C-x-x	SAC450/386-C-x-x	SAC520/386-I-x-x	SAC520/386-C-x-x
CE approved	Yes	Yes	Yes	Yes	Yes	Yes
PRO™	Yes	Yes	Yes	Yes	Yes	Yes
Control system	S-Link™	S-Link™	S-Link™	S-Link™	S-Link™	S-Link™
Q-PROP™	Yes	Yes	Yes	Yes	Yes	Yes
Propulsion system	Twin Counter	Twin Counter	Twin Counter	Twin Counter	Twin Counter	Twin Counter
Lubrication	Sealed	Sealed	Gravity feed	Gravity feed	Gravity feed	Gravity feed
Galvanic separation ²	No	No	No	No	No	No

(xx) Thrust values

Continuous thrust value: This value is the thrust available for unlimited time of operation without motor heating up to temperature limit for de-rating. Both "I" and "C" version will have this value. **Thrust max. value:** Only "I" models have a value listed in this field. This is the thrust available for a limited time until the motor temperature reach the limit for gradually de-rating of performance.

Bow	Description (mm)
(H)	Height
(L)	Length
(W)	Width
(ID)	Internal Diameter
(WD)	Water Depth
(TL)	Recommended Tunnel Length
(TL min.)	Minimum Tunnel Length
(T min.)	Minimum Tunnel Wall Thickness
(T max.)	Maximum Tunnel Wall Thickness
Stern	
(L)	Internal Length
(+L)	Tunnel Length
(WD)	Stern Water Depth
(HT)	Maximum Hull Thickness

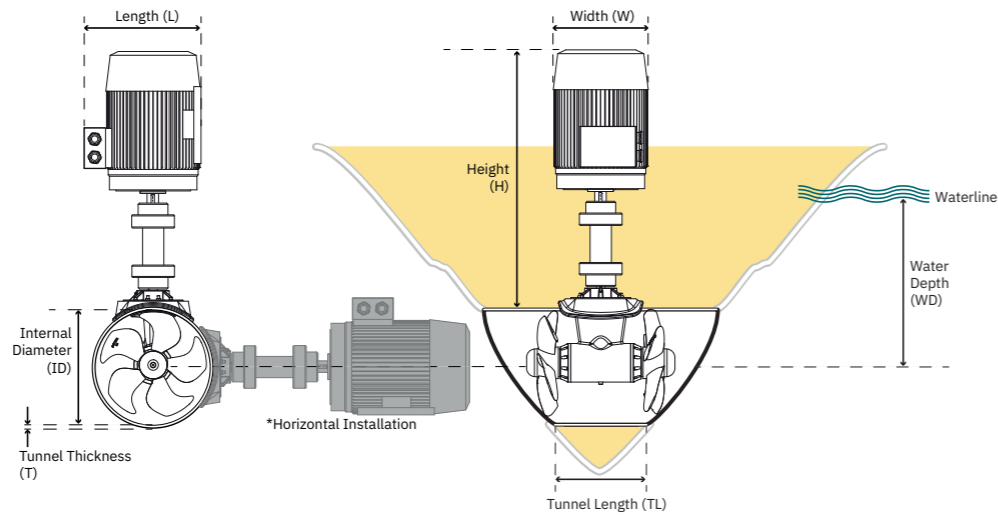

Sleipner thrusters can be installed at an angle off the vertical centre. Tailored to fit any space available in your vessel.

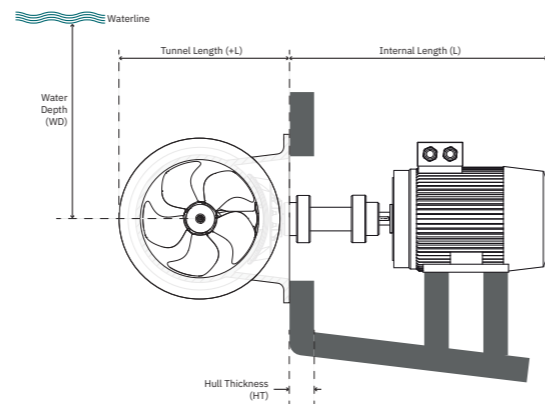

Please see note regarding thruster power and battery rating on page 114.

¹ Max thrust is available until motor temperature will reduce performance to continuous thrust rating

² Isolation kit for galvanic separation available

³ Weight stated is for complete thruster unit, excluding VFD



For heavy duty usage

SAC400/300TC	SAC700/412TC	SAC750/513TC	SAC900/513TC	SAC1100/513TC	SAC1100/513TC	SAC1300/610TC	SAC1400/610TC
400	700	600	750	900	1100	1100	1200
-	-	750	900	1100	-	1300	1400
30 • 41	42 • 57	41 • 56	53 • 72	70 • 95	70 • 95	74 • 101	83 • 113
18-33/59-108	29-44/95-145	29-44/95-145	30-45/100-150	32-49/105-160	32-49/105-160	40-52/130-170	40-55/130-175
300	412	513	513	513	513	610	610
SAC400/300-C-x-x	SAC700/412-C-x-x	SAC750/513-I-x-x	SAC900/513-I-x-x	SAC1100/513-I-x-x	SAC1100/513-C-x-x	SAC1300/610-I-x-x	SAC1400/610-I-x-x
Yes	Yes	Yes	Yes	Yes	Yes	Yes	Yes
Yes	Yes	Yes	Yes	Yes	Yes	Yes	Yes
S-Link™	S-Link™	S-Link™	S-Link™	S-Link™	S-Link™	S-Link™	S-Link™
Yes	Yes	Yes	Yes	Yes	Yes	Yes	Yes
Twin Counter	Twin Counter	Twin Counter	Twin Counter	Twin Counter	Twin Counter	Twin Counter	Twin Counter
Gravity feed	Gravity feed	Gravity feed/ On water change	Gravity feed/ On water change	Gravity feed/ On water change	Gravity feed/ On water change	Gravity feed/ On water change	Gravity feed/ On water change
No	No	No	No	No	No	No	No

Measurements (mm)	H	L	W	ID	WD	TL	TL min.	T min.	T max.	Weight ³ kg
SAC240/250 (horizontal version)	688	347	262	250	380	550	300	7	10	68
SAC240/250 (vertical version)	688	347	262	250	380	550	300	7	10	68
SAC320/300 (horizontal version)	703	347	262	300	450	550	300	10	10	71
SAC320/300 (vertical version)	703	347	262	300	450	550	300	10	10	71
SAC360/300 (horizontal version)	774	397	313	300	450	550	370	10	10	105
SAC360/300 (vertical version)	774	397	313	300	450	550	370	10	10	105
SAC400/300 (horizontal version)	774	397	313	300	450	550	370	10	10	111
SAC400/300 (vertical version)	774	397	313	300	450	550	370	10	10	111
SAC450/386 (horizontal version)	999	439	356	386	580	750	500	10	15	189
SAC450/386 (vertical version)	999	439	356	386	580	750	500	10	15	189
SAC520/386 (horizontal version)	999	439	356	386	580	750	500	10	15	189
SAC520/386 (vertical version)	999	439	356	386	580	750	500	10	15	189
SAC700/412 (horizontal version)	964	439	356	412	620	800	550	12	16	205
SAC700/412 (vertical version)	964	439	356	412	620	800	550	12	16	205
SAC750/513 (horizontal version)	1079.5	496	396	513	700	1000	750	12	22	330
SAC750/513 (vertical version)	1079.5	496	396	513	700	1000	750	12	22	330
SAC900/513 (horizontal version)	1193.5	563	449	513	700	1000	750	12	22	450
SAC900/513 (vertical version)	1193.5	563	449	513	700	1000	750	12	22	450
SAC1100/513-C (horizontal version)	1303.5	642	495	513	770	1000	750	12	22	575
SAC1100/513-C (vertical version)	1303.5	642	495	513	770	1000	750	12	22	575
SAC1100/513-I (horizontal version)	1193.5	563	449	513	770	1000	750	12	22	465
SAC1100/513-I (vertical version)	1193.5	563	449	513	770	1000	750	12	22	465
SAC1300/610 (horizontal version)	1305	712	555	610	900	1000	750	14	24	680
SAC1300/610 (vertical version)	1305	712	555	610	900	1000	750	14	24	680
SAC1400/610 (horizontal version)	1305	712	555	610	900	1000	750	14	24	740
SAC1400/610 (vertical version)	1305	712	555	610	900	1000	750	14	24	740



Hydraulic tunnel thrusters

Power from 100 kg to 1400 kg and continuous operation make a hydraulic thruster system ideal for yachts, super yachts and professional vessels. It is the natural choice when extensive thruster usage or long run cycles are required.

For all the hydraulic components to be compatible and maintain the same high quality, Sleipner offers complete hydraulic systems with guaranteed performance. Sleipner hydraulic systems use only brand-name hydraulic components, ensuring reliability and easy worldwide access to spare parts and service.

The innovative S-Link™ control system ensures fast and trouble-free installation, and gives you the unique option to combine hydraulic and AC thrusters in a single control environment.

All hydraulic systems are delivered ready-to-use to provide a straightforward installation and the highest degree of quality assurance.



We offer complete hydraulic systems. Scan QR code to learn more

Benefits

- Continuous use
- Controlled power
- Reliability
- S-Link™ operating system
- Custom-made, ready to install with Plug & Play wiring
- The choice of leading boatbuilders
- Full documentation
- DNV type approval for specific models
- Suitable for joystick and DP integration



Specific models



Product features

- S-LINK™
- SEALED DRIVE LUBRICATION
- GRAVITY FEED LUBRICATION
- Q-PROP™
- PRO™

Technical details

Ideal Vessel Class	Motor boat, Sail boat
Ideal Vessel Size	9–55 m / 30–175 ft
Power	HYD
Thrust light duty	100–1100kg / 220–2425 lbs
Thrust heavy duty	80–1400 kg / 176–3085 lbs
Tunnel diameter	185–610 mm
Placement	Bow / Stern



For leisure usage

	SH100/185T	SH160/215T	SH240/250TC	SH320/300TC	SH360/300TC
Light duty thrust (kg)	100	160	240	320	-
Heavy duty thrust (kg)	80	140	220	270	360
Ideal Vessel Size (m/ft)	9-16/30-34	11-19/35-62	13-23/42-75	17-31/55-100	18-33/59-108
(ID) Internal Diameter (mm)	185	215	250	300	300
Power Output (kW • Hp)	6.9 • 9.3	10.0 • 13.4	14.9 • 20	17.4 • 23.3	27 • 37
Q-PROP™	Yes	Yes	Yes	Yes	Yes
Propulsion system	Twin	Twin	Twin Counter	Twin Counter	Twin Counter
Lubrication	Sealed	Sealed	Sealed	Sealed	Gravity feed

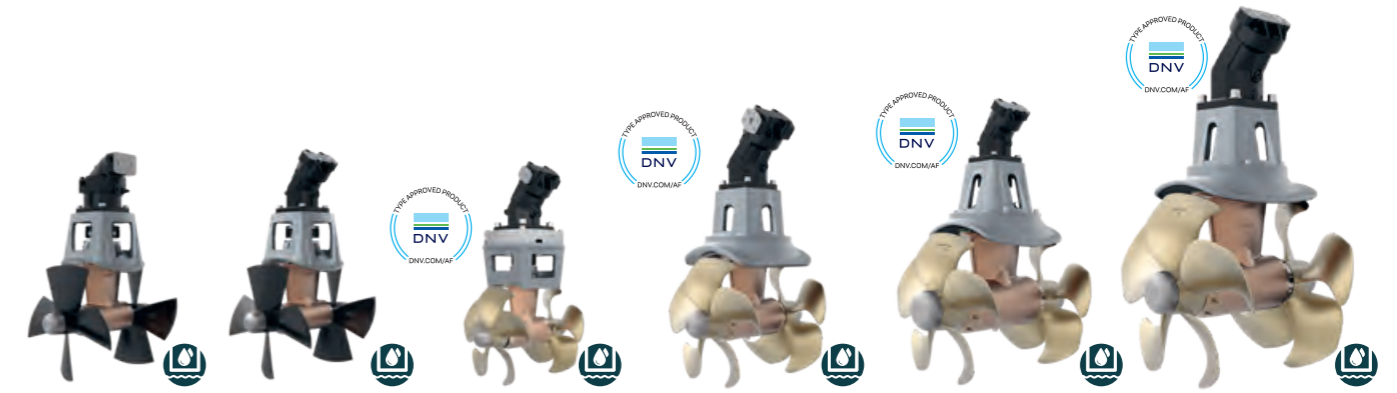

For leisure usage

For heavy duty usage

	SH420/386TC	SH 550/386TC	SH400/300TC	SH 700/412TC	SH 1000/513TC	SH 1400/610TC
Light duty thrust (kg)	-	550	-	-	1100	-
Heavy duty thrust (kg)	420	500	400	700	1000	1400
Ideal Vessel Size (m/ft)	22-35/75-110	25-40/85-140	18-33/59-108	29-44/95-145	30-45/100-150	40-55/130-175
(ID) Internal Diameter (mm)	386	386	300	412	513	610
Power Output (kW • Hp)	31.8 • 42.6	39.9 • 53.5	30 • 41	43.4 • 58.2	59.8 • 80.2	80.1 • 107.4
Q-PROP™	Yes	Yes	Yes	Yes	Yes	Yes
Propulsion system	Twin Counter	Twin Counter	Twin Counter	Twin Counter	Twin Counter	Twin Counter
Lubrication	Gravity feed	Gravity feed	Gravity feed	Gravity feed	Gravity feed/On water change	Gravity feed/On water change

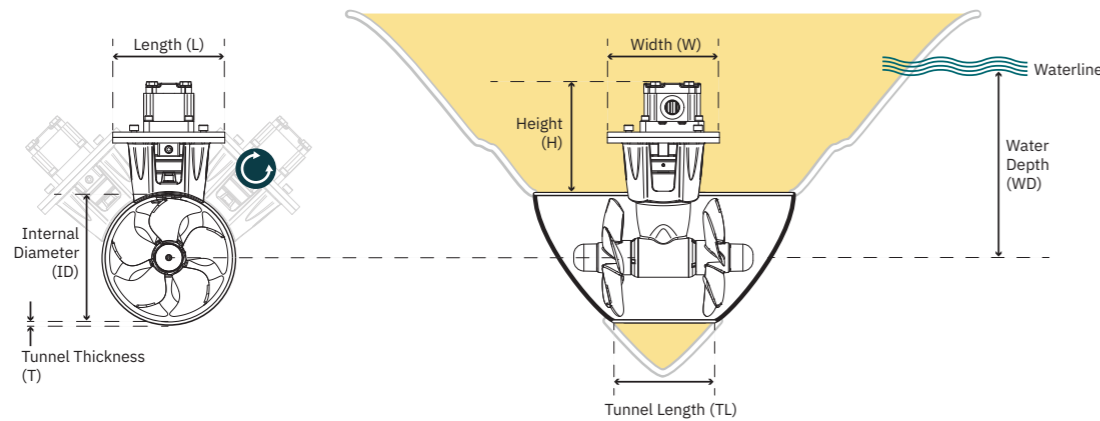

Sleipner thrusters can be installed at an angle off the vertical centre. Tailored to fit any space available in your vessel.

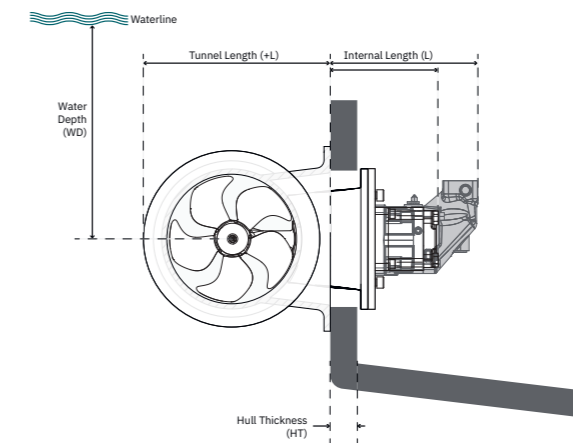

Bow	SH100/185T	SH160/215T	SH240/250TC	SH320/300TC	SH360/300TC
(ID) Internal Diameter (mm)	185	215	250	300	300
Weight ¹ (kg)	7.8	11.4	13.5	17.16	26
(H) Height (mm)	215	195	235	245	356
(L) Length (mm)	203	203	203	258	258
(W) Width (mm)	203	203	203	258	258
(ID) Internal Diameter (mm)	185	215	250	300	300
(WD) Water Depth (mm)	200	215	250	300	450
(TL) Rec. Tunnel Length (mm)	340	560	600	550	550
(TL min.) Minimum Tunnel Length (mm)	170	280	300	370	370
(T min.) Min. Tunnel Wall Thickness	4	6	7	10	10

Stern	SH100/185T	SH 160/215 T	SH 240/250 TC	SH 320/300TC	SH 360/300 TC
(L) Internal Length (mm)	405	172	912	195	310
(+L) Tunnel Length (mm)	705	300	340	420	420
(WD) Stern Water Depth (mm)	770	215	250	300	300
(HT) Maximum Hull Thickness	120	54	60	60	60
Stern thruster kit	90086i	90135i	90140i	90200i	90350
Cowls - short model	90075	-	-	-	-
Cowls - long model	90077	90136	90132	90220	-

¹ Weight of hydraulic motor comes in addition

	SH420/386TC	SH 550/386TC	SH400/300TC	SH 700/412TC	SH 1000/513TC	SH 1400/610TC
Light duty thrust (kg)	386	386	300	412	513	610
Heavy duty thrust (kg)	46	56	31	72-76	168-182	211
Ideal Vessel Size (m/ft)	369	369	356	450	486	500
(ID) Internal Diameter (mm)	268	268	258	268	398	398
(WD) Water Depth (mm)	268	268	258	268	398	398
(L) Internal Length (mm)	386	386	300	412	513	610
(+L) Tunnel Length (mm)	580	580	450	620	750	900
(WD) Stern Water Depth (mm)	750	750	550	800	1000	1000
(TL min.) Minimum Tunnel Length (mm)	500	500	370	550	750	750
(T min.) Min. Tunnel Wall Thickness	10	10	10	16	16	18

	SH 420/386 TC	SH 550/386TC	SH 400/300TC	SH 700/412TC	SH 1000/513TC	SH 1400/610TC
(L) Internal Length (mm)	257	257	305	n. a.	405	470
(+L) Tunnel Length (mm)	540	540	422	n. a.	705	820
(WD) Stern Water Depth (mm)	380	380	300	n. a.	770	915
(HT) Maximum Hull Thickness	54	54	60	n. a.	120	145
Stern thruster kit	90550	90550	90350	90700	91000	91400
Cowls - short model	-	-	N/A	N/A	N/A	N/A
Cowls - long model	90560	90560	N/A	N/A	N/A	N/A



Hydraulic power systems

Sleipner's hydraulic power systems are designed for ultimate flexibility to support all hydraulic components onboard, including thrusters and stabilizers. A hydraulic system offers immense savings on space and labor cost, considering that essentially all necessary parts are pre-installed, wired, and adjusted.

A hydraulic system makes sound economic sense for many vessels as several functions can run off one central hydraulic source. Once the primary system is in place, including the pump, reservoir, and cooler, adding a function is simply a matter of adding a relatively inexpensive hydraulic valve. This approach is more efficient and cost-effective than running each part with its own electric motor, solenoid, fuse, and battery switch, especially with larger equipment.

Hydraulic valves and motors are better choices in harsh environments such as the forepeak, bilge, and transom areas and areas requiring ignition protection. Typical hydraulic applications are thrusters, stabilizers, winches, capstans, cranes, and so on.

For all the hydraulic components to be compatible and maintain the same high quality, Sleipner offers complete

hydraulic systems with guaranteed performance. Sleipner hydraulic systems use only brand-name hydraulic components, ensuring reliability and easy worldwide access to spare parts and service.

The hydraulic pumps are based on the well-proven and reliable load sense principle, ensuring high efficiency, low noise, and low heat generation.

The system's brain is the PHC-3 with real-time component diagnostics on both the integrated LCD panel and at the helm. Installed directly on the tank, it provides below deck access to diagnostics and local configuration of parameters.

All hydraulic systems are delivered ready-to-use to provide a straightforward installation and the highest degree of quality assurance.



Benefits

- Compact-sized units and easy maintenance
- Delivered pre-fitted with all components adjusted
- Advanced real-time diagnostics
- S-Link™ operating system
- Plug & Play wiring
- Available as standard or customized by our hydraulic expert engineers
- Bulkhead and floor installation options
- Delivered with complete system-specific documentation
- Load sensing hydraulic pumps for optimal efficiency
- Easy firmware update through S-Link™

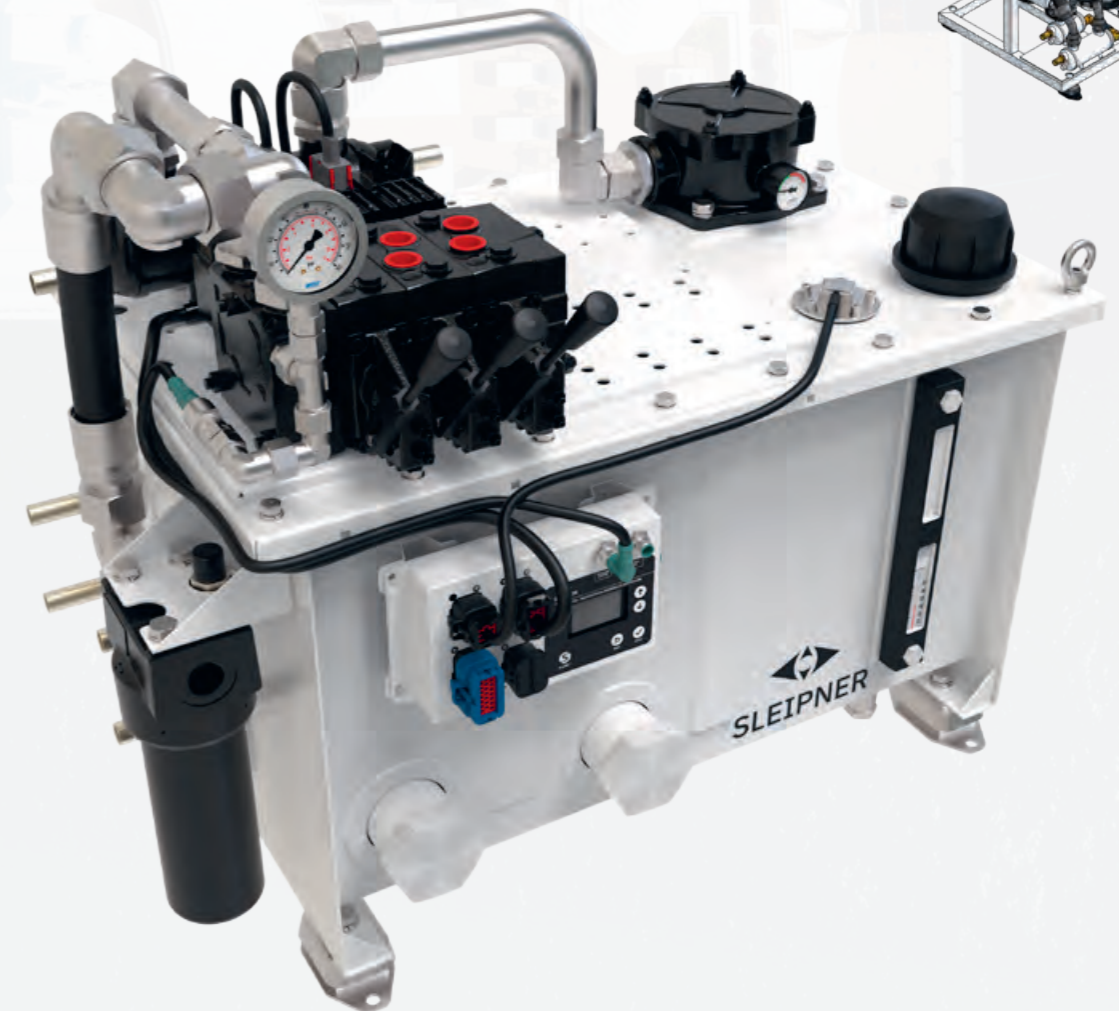
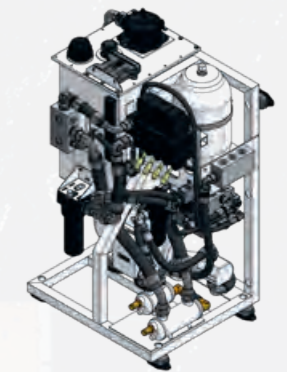
Illustration of rack assembly version for stabilizers and hydraulic thrusters



Product features

-  HYDRAULIC
-  S-LINK™
-  DIAGNOSTIC MONITORING

Technical details

Ideal Vessel Class	Yacht, Super Yacht, Commercial
Ideal Vessel Size	9–55 m / 30–175 ft
Power Source	Main engine / Generator
Reservoir	Powder coated stainless steel
Placement	Bulkhead / Floor
Control System	S-Link™

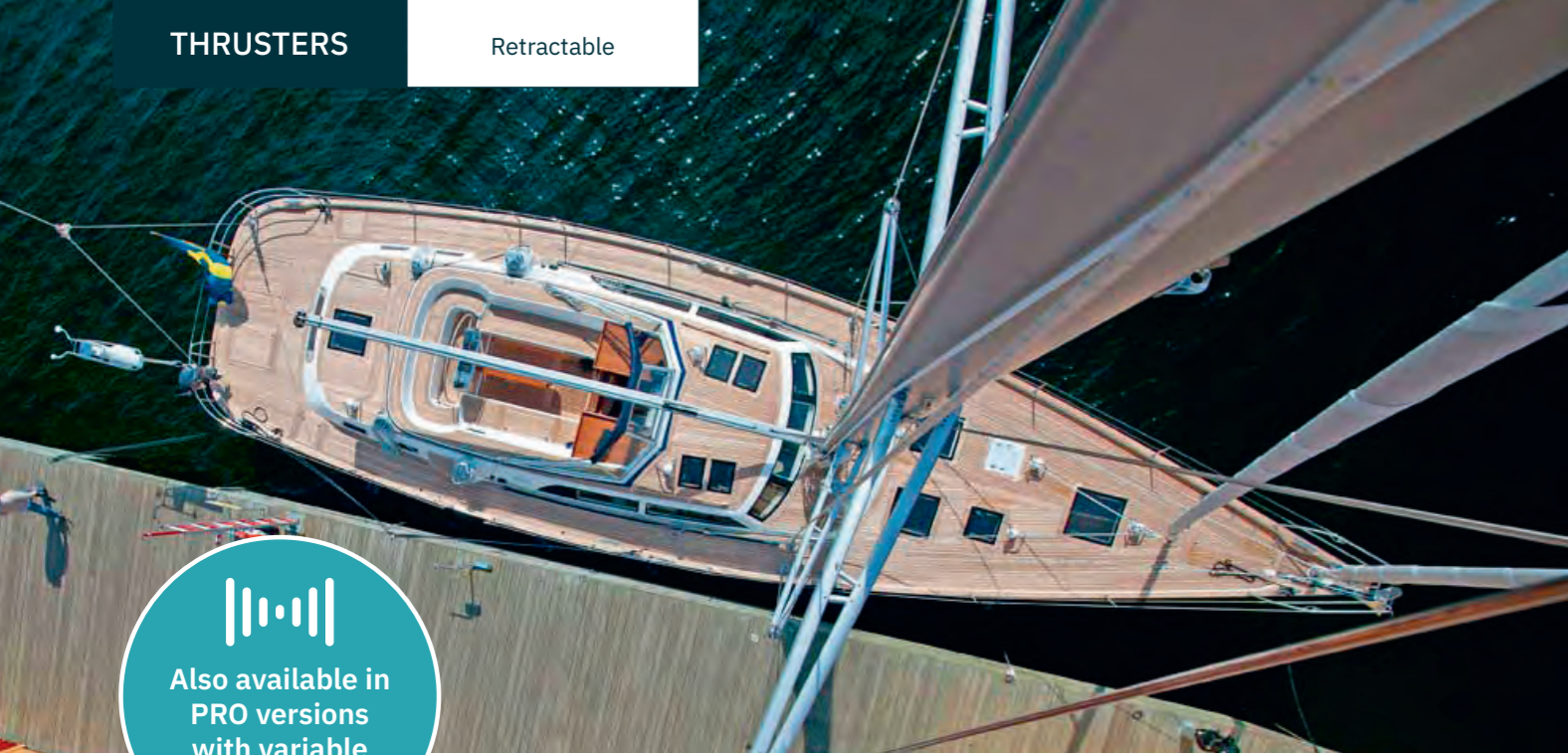

Also available in PRO versions with variable speed control

Retractable thrusters

The obvious solution for cruiser-racers and flat-bottomed boats. Sleipner's retractable thrusters are designed with a focus on practical sturdiness, uncompromised safety and quick deployment.

If you have a performance boat, sail, or power, and you're worried about the smallest amounts of drag, a retractable thruster is the perfect solution for you.

The retracting thrusters are generally built with the same high safety standards as all Sleipner products. Our focus on safety is a totally integral part of the product design so that everything from build quality to ease of installation is thought of to ensure long term reliability.

There are three versions of the retractable thrusters, one model design for direct mold-in, and two designed to be mounted on a flange. The flange can be a mold-in base from Sleipner, or the boat builders can manufacture their own base in materials suited for their hulls or as part of their basic hull design.

The flange mounted models have a thruster unit in a casing that will be bolted to a base. This allows for easier installation in hulls made from different materials, as well as in series production where you do not need to mix laminating and engineering type jobs.

The underwater mechanism's unique design has only a few but very sturdy parts contributing to the moving assembly's stability. The unit's design makes the thruster as compact as possible while enabling the safe use of heavier motors on the more powerful units. The motors' vertical installation (SRV) reduces the impact forces on the assembly in extreme waves compared to motors fitted at an angle.

If height limitation is an issue on your vessel, the SRL has the market's most compact build concerning height.

Benefits

- Fitted as bow and/or stern thruster
- Quiet operation
- Plug and play S-Link™ two way communication control cable wiring
- Easy to use control panel with status feedback from thruster
- Motor assembly rigid mounted on retracting casing - no moving parts during retracting operation
- Reliable retracting mechanism, avoids sticking
- Fast deployment time
- Compact size



Scan and watch
See customer reviews on our video channel

Product features

- INTELLIGENT POWER CONTROL
- SEALED DRIVE LUBRICATION
- GALVANIC SEPARATION
- Q-PROP™
- S-Link™
- GRAVITY FEED LUBRICATION (Ø300 MM TUNNELS)

Technical details

Ideal Vessel Class	Motor boat, Sail boat
Ideal Vessel Size	25–46m / 85–150ft
Power	DC 12/24/48V
Thrust	80–340kg / 212–749lbs
Tunneldiameter	185–386 mm
Placement	Bow / Stern



ER Thruster*	ERL100/185T	ERL130/250T	ERL170/250TC	ERV100/185T	ERV130/250TC
	24/48V	24/48V	24/48V	24/48V	24/48V
Thrust at 24V/48 (kg)	100	130	170	100	130
Thrust at 21/42V (kg)	100	130	170	100	130
Ideal Vessel Size (m/ft)	12-17/35-55	13-19/42-62	15-22/50-70	12-17/35-55	13-19/42-62
(ID) Internal Diameter (mm)	185	250	250	185	250
Propulsion System	Twin	Twin	Twin	Twin	Twin
Power Output (kW • Hp)	5.6 • 7.6	5.1 • 6.8	7.3 • 9.9	6.3 • 8.4	5.1 • 6.8
Power requirement (V)	12/24V	12/24V	12/24V	12/24V	12/24V
Weight (kg)	51.7/51.5	92.5/92.3	93.0/92.8	44.4/44.2	83.4/83.2
Min. Battery CCA (DIN)	300/150	300/180	420/255	300/150	300/180
Item Code 24V	ERL100/185T-24V	ERL130/250T-24V	ERL170/250TC-24V	ERV100/185T-24V	ERV130/250T-24V
Item Code 48V	ERL100/185T-48V	ERL130/250T-48V	ERL170/250TC-48V	ERV100/185T-48V	ERV130/250T-48V

ERV170/250TC	ERV210/250TC	ERV250/300TC	ERV300/300TC
24/48V	24/48V	48V	48V
170	210	250	300
170	210	250	300
15-22/50-70	17-24/55-78	22-30/72-100	22-30/72-100
250	250	300	300
Twin	Twin Counter	Twin	Twin
7.3 • 9.9	10.4 • 14.0	15 • 20	15 • 20
12/24V	24V	48V	48V
83.9/ 83.7	90.8/90.6	122.3	122.3
420/220	600/320	350	395
ERV170/250TC-24V	ERV210/250TC-24V	ERV250/300TC-24V	
ERV170/250TC-48V	ERV210/250TC-48V	ERV250/300TC-48V	ERV300/300TC-48V

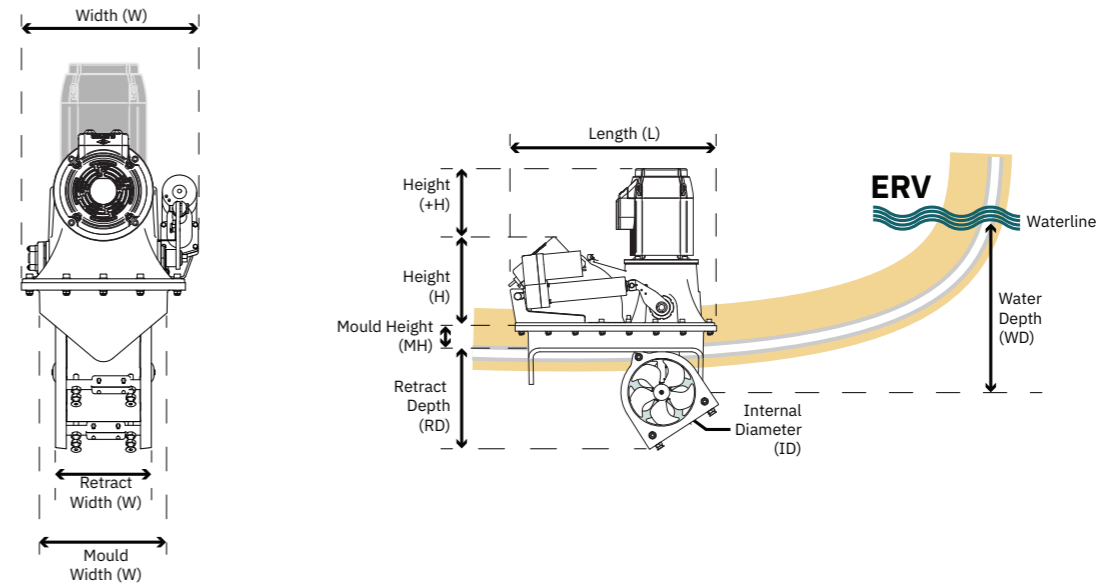
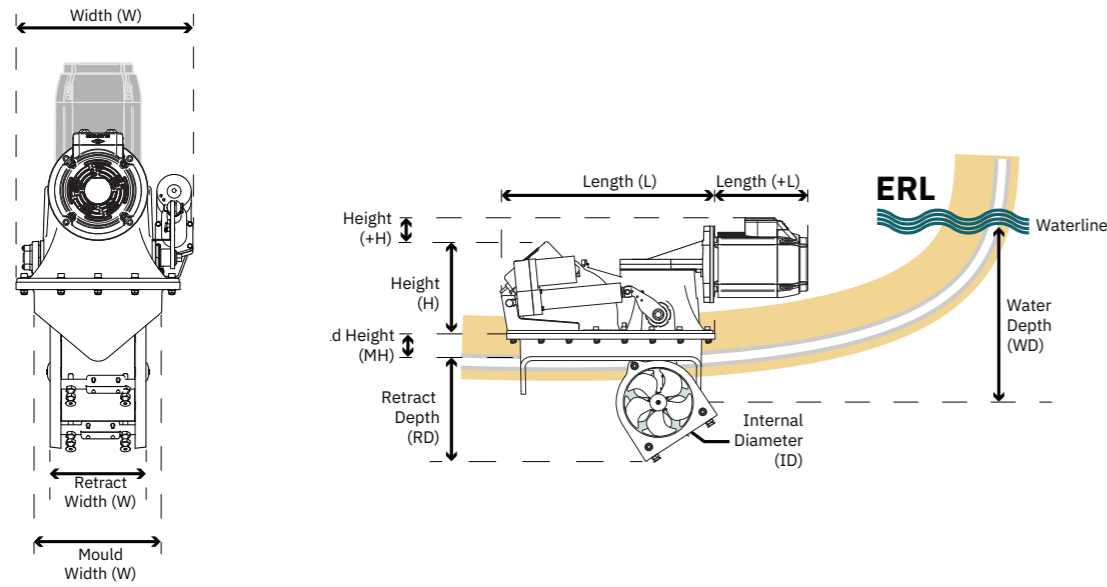

ER DC	ERL100/185T	ERL130/250T	ERL170/250TC	ERV100/185T	ERV130/250TC	ERV170/250TC	ERV210/250TC
	24/48V	24/48V	24/48V	24/48V	24/48V	24/48V	24/48V
(H) Height (mm)	245	389	389	245	389	389	389
(+H) Add.Height (mm)	94	9	9	232	120	120	159
(L) Length (mm)	563	687	687	563	687	687	687
(+L) Add. Length (mm)	293	281	281	-	-	-	-
(W) Width (mm)	359	480	481	356/359	481	481	481
(ID) Internal Diam. (mm)	185	250	250	185	250	250	250
(WD) Water Depth (mm)	185	250	250	185	250	250	250
(RD) Retract Depth (mm)	275	378	378	271	378	378	378
(RW) Retract Width (mm)	195	349	349	195	349	349	349
(MW) Mould Width (mm)	265	417	417	265	417	417	417
(MH) Mould Height (mm)	62	91	91	62	91/98	98	98

ERV250/300TC	ERV300/300TC
48V	48V
453	453
117	117
843	843
-	-
580	580
300	300
300	300
454	454
415	415
486	486
106	106

Please see note regarding thruster power and battery rating on page 119.



SR SERIES DC	SR80	SR100	SRL80	SRL100	SRL130	SRL170
Thrust at 12/24V (kg)	96	116	96	116	160	210
Thrust at 10.5/21V (kg)	80	100	80	100	130	170
Ideal Vessel Size (m/ft)	10-15/35-48	12-17/35-55	10-15/35-48	12-17/35-55	13-19/42-62	15-22/50-70
Internal Diameter (mm)	185	185	185	185	250	250
Propulsion System	Twin	Twin	Twin	Twin	Twin	Twin Counter
Power Output (kW • Hp)	4.4 • 6	6.3 • 8.4	4.4 • 6	6.3 • 8.4	6.5 • 8.7	8 • 11.8
Power requirement (V)	12/24V	12/24V	12/24V	12/24V	12/24V	24V
Weight (kg)	31	44	31	44	82	88
Min. Battery CCA* (DIN)	550/300	750/400	550/300	750/400	750/400	560



SRV80	SRV100	SRV130	SRV170	SRV210	SRV300
12/24V	12/24V	12/24V	24V	24V	48V
96	116	160	210	250	340
80	100	130	170	210	300
10-15/35-48	12-17/35-55	13-19/42-62	15-22/50-70	17-24/55-78	22-30/72-98
185	185	250	250	250	300
Twin	Twin	Twin	Twin Counter	Twin Counter	Twin Counter
4.4 • 6	6.3 • 8.4	6.5 • 8.7	8 • 11.8	10 • 13.5	15 • 20
12/24V	12/24V	12/24V	24V	24V	48V
31	44	82	88	112	120
550/300	750/400	750/400	560	560	400

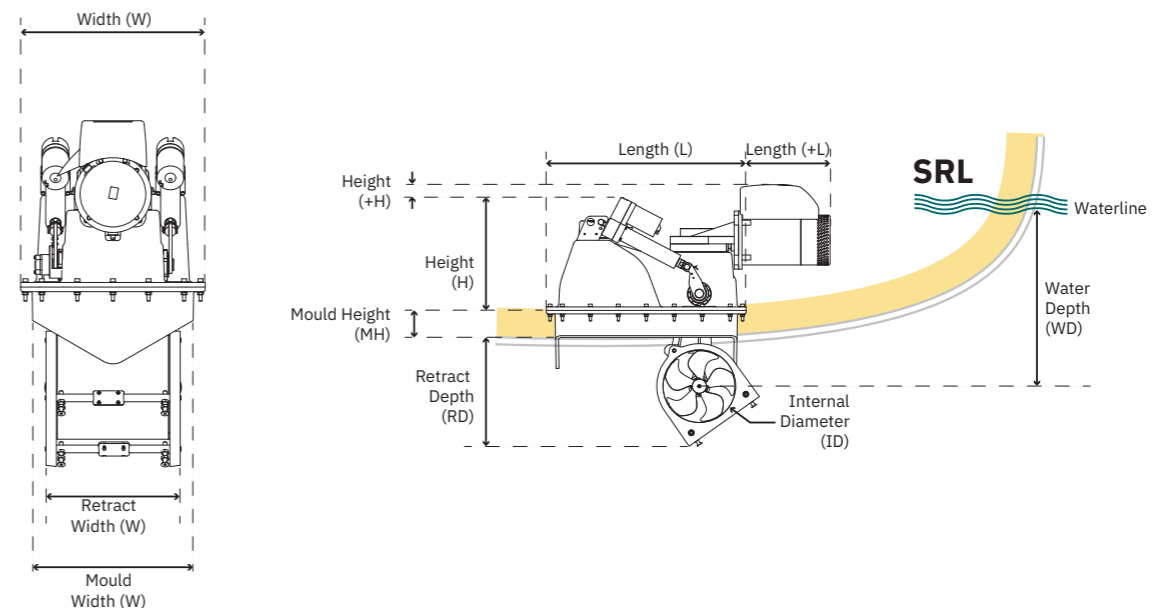
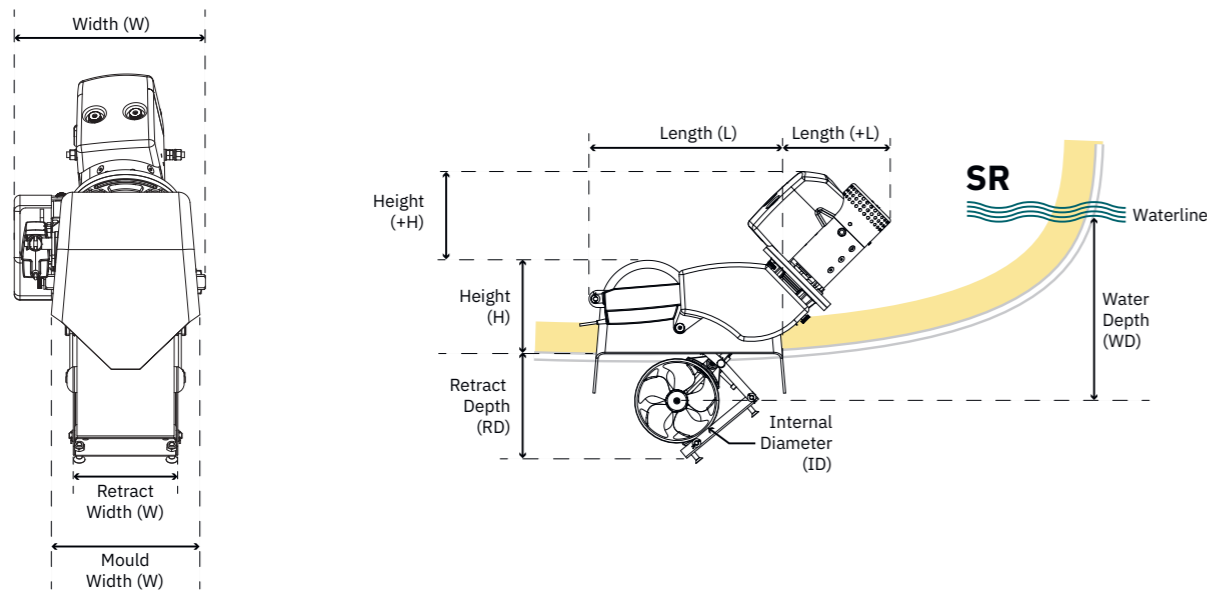

SR DC	SR80	SR100	SRL80	SRL100	SRL130	SRL170	SRV80	SRV100	SRV130	SRV170	SRV210	SRV300
	12/24V	12/24V	12/24V	12/24V	12/24V	24V	12/24V	12/24V	12/24V	24V	24V	48V
(H) Height (mm)	245	245	243	243	391/390	389	243	243	390	390	389	452
(+H) Add.Height (mm)	167/170	212/205	93/96	129/128	23	44	169/184	226/221	104/110	128	211	172
(L) Length (mm)	459	459	561	561	688	688	561	561	688	688	688	843
(+L) Add. Length (mm)	260/244	258/288	230/245	287/281	264/269	289	-	-	-	-	-	-
(W) Width (mm)	335	335	359	359	480	480	359	359	480	480	480	580
(ID) Internal Diam. (mm)	185	185	185	185	250	250	185	185	250	250	250	300
(WD) Water Depth (mm)	185	185	185	185	250	250	185	185	250	250	250	300
(RD) Retract Depth (mm)	278	278	276	276	374	374	276	276	374	374	374	445
(RW) Retract Width (mm)	183	183	195	195	348	348	195	195	348	348	348	415
(MW) Mould Width (mm)	260	260	257	257	420	420	257	257	420	420	420	480
(MH) Mould Height (mm)	-	-	62	62	93	93	62	62	93	93	93	115

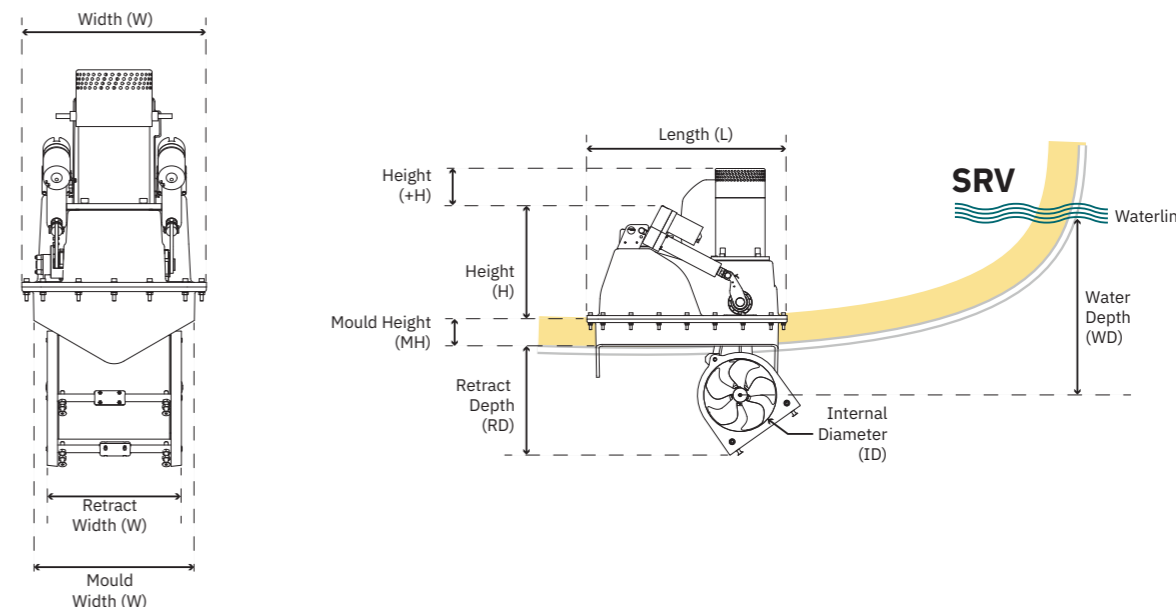

Please see note regarding thruster power and battery rating on page 114.



	SRAC320	SRHP240	SRHP320	SRHP650
Light Duty Thrust (kg)	320	240	320	650
Ideal Vessel Size (m/ft)	22-34/72-110	13-23/42-75	22-34/72-110	25-46/85-150
Internal Diameter (mm)	300	250	300	386
Power Output (kW• Hp)	21 • 27	14 • 19	21 • 27	47 • 64
Motor	230/400V 3-phase	HYD	HYD	HYD
Weight (kg)	140	82	88	300
Installation	Flange	Flange	Flange	Flange
Control System	S-Link™	S-Link™	S-Link™	S-Link™
Propulsion System	Twin Counter Rotating	Twin Counter Rotating	Twin Counter Rotating	Twin Counter Rotating

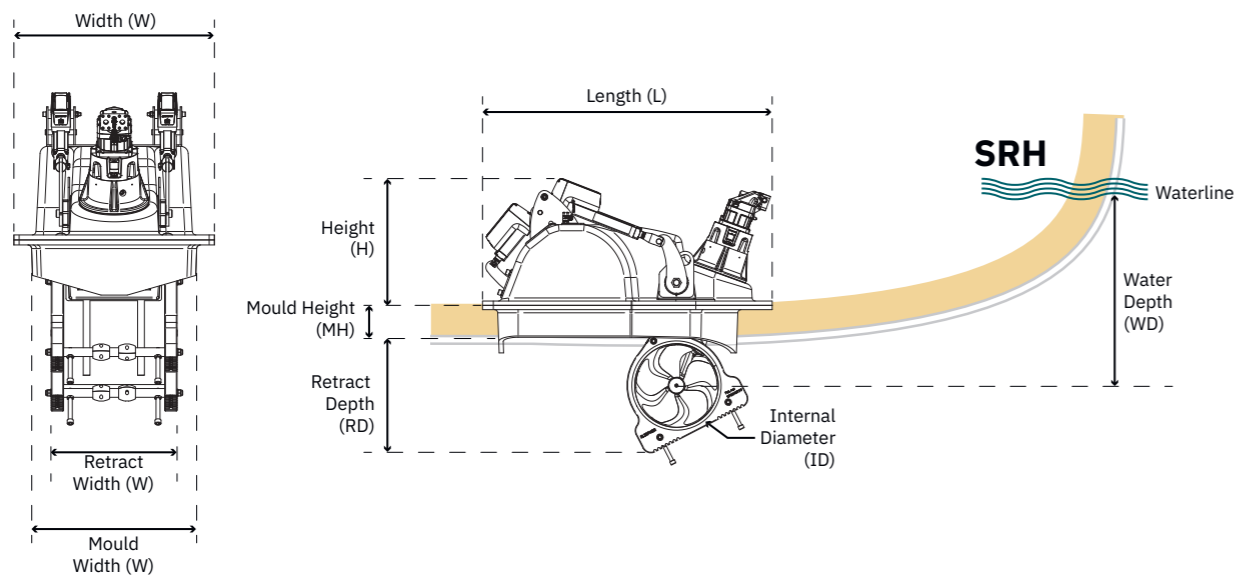

	SRAC320	SRHP240	SRHP320/300TC	SRHP650/386TC
	AC electric	Hydraulic	Hydraulic	Hydraulic
(H) Height (mm)	455	390	455	590
(L) Length (mm)	843	688	843	1340
(W) Width (mm)	580	481	580	800
(ID) Internal Diameter (mm)	300	250	300	386
(WD) Water Depth (mm)	300	250	300	386
(RD) Retract Depth (mm)	445	361	445	355
(RW) Retract Width (mm)	415	347	415	548
(MW) Mould Width (mm)	480	414	480	651
(MH) Mould Height (mm)	115	98	115	148

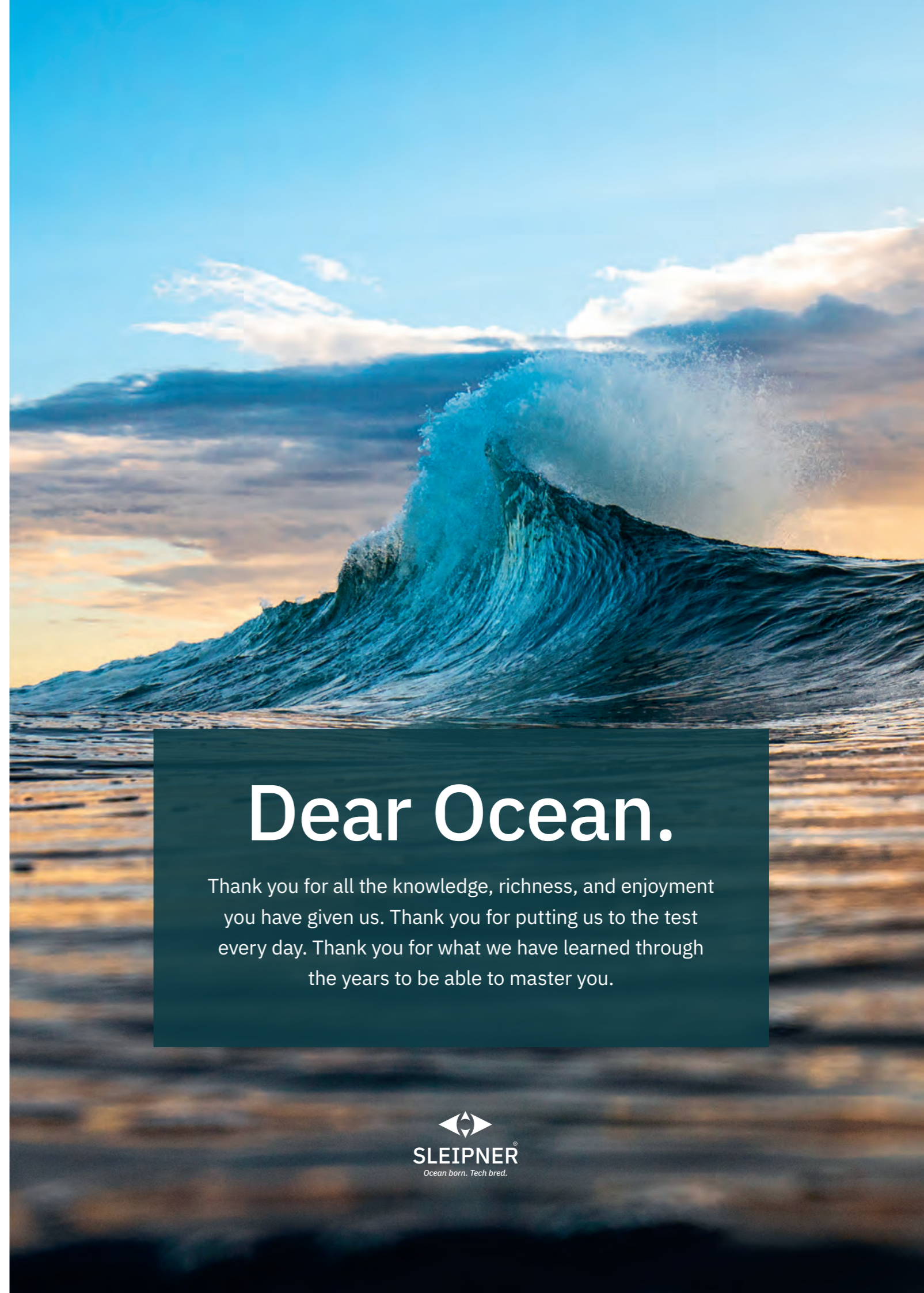

Dear Ocean.

Thank you for all the knowledge, richness, and enjoyment you have given us. Thank you for putting us to the test every day. Thank you for what we have learned through the years to be able to master you.





External thrusters

Sleipner's external thrusters are as compact as it gets and offer many attractive benefits for boat builders as well as retrofit installations. The versatile installation and compact size make them the perfect choice for vessels where the inside configuration does not allow for a standard thruster installation.

DC electric external thrusters are typically mounted underneath the hull in a streamlined hydrodynamic pod as a bow and stern thruster and are best suited on displacement or semi-planning hulls. The optimal design adds minimal drag and will, in most installations, not be noticeable.

Due to their positioning at the outermost extremities of a hull, exterior-mounted thrusters benefit significantly from an increased leverage arm in relation to the pivot point on a boat's hull. Their greater efficiency means they can move larger size boats by requiring nominally less power than conventional thrusters.

The dedicated stern thruster models save internal space, install quickly, and can be fitted with cowls if necessary to direct water flow away from any

obstacles on the stern. With the latest addition of the SX35 and SX50 to Sleipner's external thruster program, even more, boats can find space for a stern thruster as these units are the world's most compact external thrusters.

Shared benefits for external thrusters are longer run times, as the surrounding water naturally cools the units. They offer quick and easy installation without the need for fiberglass work.

Another benefit is that these thrusters operate remarkably quiet with their short, optimal tunnel design and submerged placement.

If you previously could not fit a thruster, these models might offer you the perfect solution you have been missing.

Benefits

- Fits where other thrusters won't
- Easy installation that fits many hull shapes and materials. No fiberglass works necessary
- Patented Intelligent Power Control (IPC) protection
- Ultra compact
- Minimal noise emission
- Ignition protected
- Long run times
- Optimal efficiency
- Minimal drag
- Fitted as bow and/or stern thruster



SX35/50



SX80/100

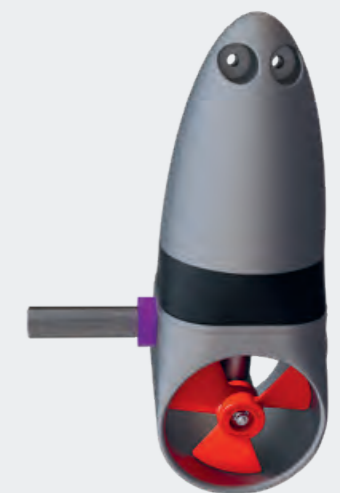

EX SINGLE/COMPACT/DUAL

Product features

- IGNITION PROTECTION
- INTELLIGENT POWER CONTROL
- SEALED DRIVE LUBRICATION
- GALVANIC SEPARATION
- Q-PROP™

Technical details

Ideal Vessel Class	Motor boat, Sail boat
Ideal Vessel Size	6–18 m / 20–59 ft
Power	DC 12/24V
Thrust	42–116 kg / 93–256 lbs
Tunnel diameter	140–185 mm
Placement	Bow / Stern



	SX35/140 50MM	SX35/140 150MM	SX50/140 50MM	SX50/140 150MM	SX35/140 50POD	SX50/140 50POD
Thrust at 12/24V (kg)	42	42	62	62	42	62
Thrust at 10.5/21V (kg)	35	35	50	50	35	50
Ideal Vessel Size (m/ft)	6-10/19-32	6-10/19-32	8-11/27-37	8-11/27-37	6-10/19-32	8-11/27-37
Internal diameter (mm)	140	140	140	140	140	140
Propulsion System	Single	Single	Single	Single	Single	Single
Power Output (kW • Hp)	1.8 • 2	1.8 • 2	2.8 • 3.75	2.8 • 3.75	1.8 • 2	2.8 • 3.75
Power requirement (V)	12V	12V	12V	12V	12V	12V
Weight (kg)	15.3	15.3	15.3	15.3	15.3	15.3
Min. Battery CCA (DIN)	200	200	350	350	200	350
Item Code 12V	SX35/140-12V-50MM	SX35/140-12V-150MM	SX50/140-12V-50MM	SX50/140-12V-150MM	SX35/140-12V-50POD	SX50/140-12V-50POD
Item Code 24V	-	-	-	-	-	-
Item Code 12V PRO	SXP35/140-12V-50MM	SXP35/140-12V-150MM	SXP50/140-12V-50MM	SXP50/140-12V-150MM	SXP35/140	SXP50/140
Item Code 24V PRO	-	-	-	-	-	-
Cowls	COWL-SX35/50	COWL-SX35/50	COWL-SX35/50	COWL-SX35/50	COWL-SX35/50	COWL-SX35/50

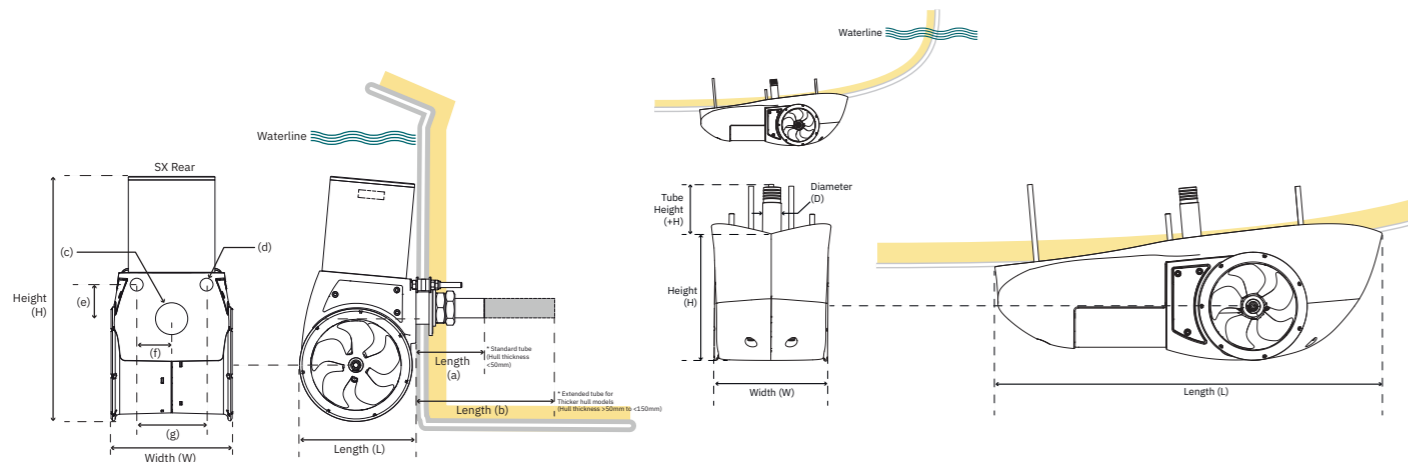

	SX35/140 -12V-50MM	SX35/140 -12V-150MM	SX50/140 -12V-50MM	SX50/140 -12V-150MM	SX35/140 -12V-50POD	SX50/140 -12V-50POD
(H) Height (mm)	374	374	374	374	180	180
(+H) Additional Height (mm)	-	-	-	-	183	183
(L) Length (mm)	171	171	171	171	630	630
(+L) Additional Length (mm)	171	276	171	276	-	-
(W) Width (mm)	183	183	183	183	183	183
(a)	108	108	108	108	-	-
(b)	276	276	276	276	-	-
(c)	50	50	50	50	-	-
(d)	18	18	18	18	-	-
(e)	35.8	35.8	35.8	35.8	-	-
(f)	65	65	65	65	-	-
(g)	130	130	130	130	-	-

Please see note regarding thruster power and battery rating on page 116.

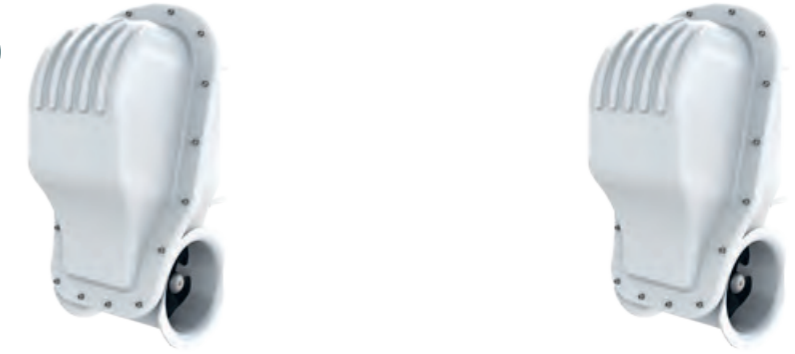

	SX 80/185 T	SX 100/185 T
Thrust at 12/24V (kg)	96	116
Thrust at 10.5/21V (kg)	80	100
Ideal Vessel Size (m/ft)	10-15/35-48	12-17/35-55
(ID) Internal Diameter (mm)	185	185
Propulsion System	Twin	Twin
Power Output (kW • Hp)	4.4 • 5.9	6 • 8.05
Power requirement (V)	12/24	12/24
Weight (kg)	52	57
Min. Battery CCA (DIN)	550	750
Item Code 12V	SX80/185T-12V	SX100/185T-12V
Item Code 24V	SX80/185T-24V	SX100/185T-24V
Item Code 12V PRO	SXP80/185T-12V	SXP100/185T-12V
Item Code 24V PRO	SXP80/185T-24V	SXP100/185T-24V
Cowls	90080	90080

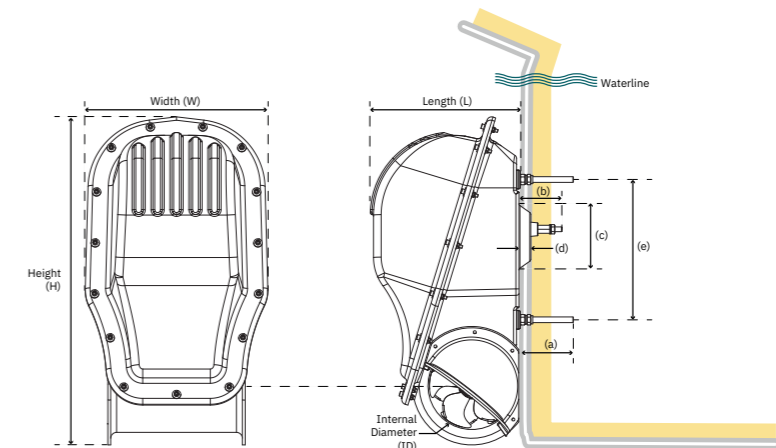

	SX80	SX100
	12/24V	12/24V
(H) Height (mm)	692	692
(+H) Additional Height (mm)	-	-
(L) Length (mm)	314	314
(+L) Additional Length (mm)	-	-
(W) Width (mm)	361	361
(ID) Internal diameter (mm)	185	185
(a)	115	115
(b)	91	91
(c)	140	140
(d)	25	25
(e)	296	296



	EX70C	EX95S
Thrust at 12/24V (kg)	67	67
Thrust at 10.5/21V (kg)	-	-
Ideal Vessel Size (m/ft)	10-15/35-48	10-15/35-48
Internal Diameter (mm)	150	150
Propulsion system	Single	Single
Power Output (kW • Hp)	3.0 • 4.0	3.0 • 4.0
Power requirement (V)	24	24
Weight (kg)	19.5	19.5
Min. Batt. Cap CCA (DIN)	190	190
Item Code 12V	-	-
Item Code 24V	EX70C	EX95S



	EX180D
Thrust at 12/24V (kg)	180
Thrust at 10.5/21V (kg)	130
Ideal Vessel Size (m/ft)	14-18/44-59
Internal Diameter (mm)	150
Propulsion System	Dual
Power Output (kW • Hp)	6.0 • 8.0
Power requirement (V)	24
Weight (kg)	35
Min. Batt. Cap CCA DIN	375
Item Code 12V	-
Item Code 24V	EX180D

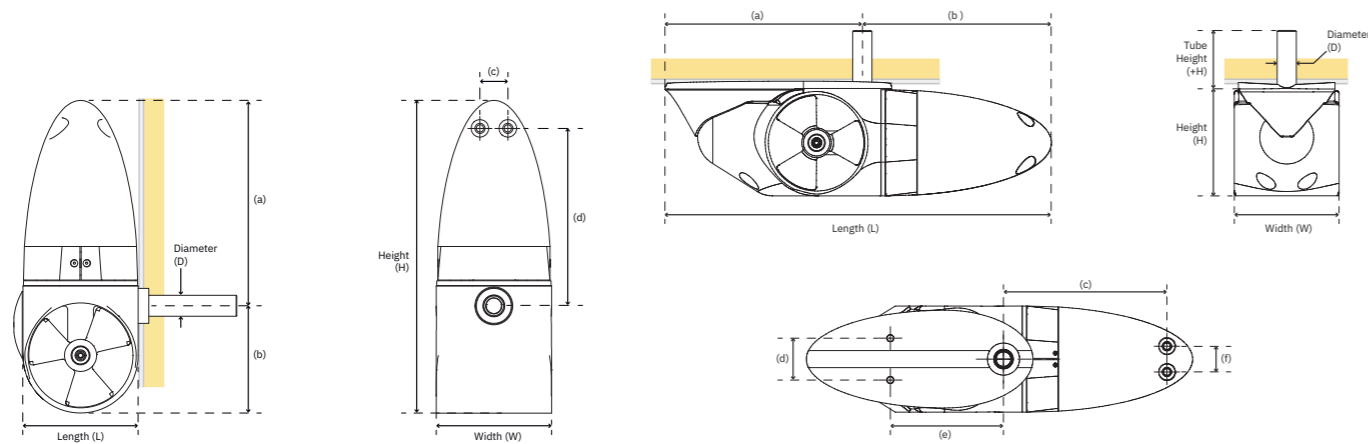

Measurements	EX70C	EX95S
mm	24V	24V
(H) Height	447	165
(+H) Additional Height	-	137.5
(L) Length	165	600
(+L) Additional Length	-	-
(W) Width	165	165
(a)	294	306
(b)	153.5	294
(c)	40	137.5
(d)	254	65
(e)	-	176
(f)	-	254
(g)	-	40

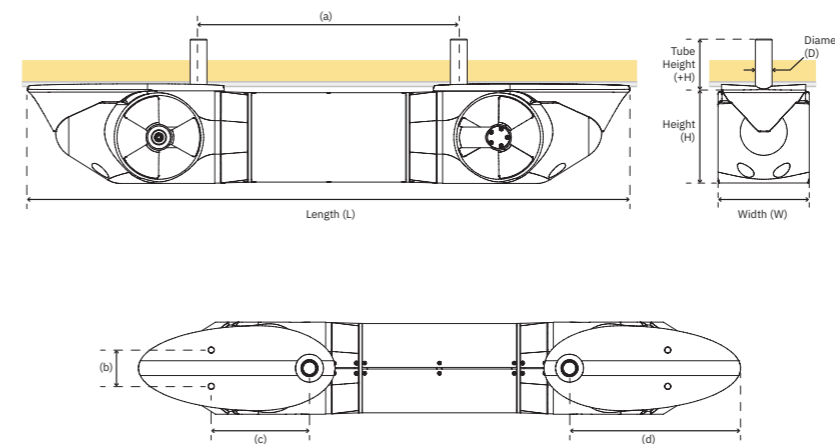

Measurements	EX180D
mm	24V
(H) Height	165
(+H) Additional Height	152
(L) Length	1079
(+L) Additional Length	-
(W) Width	165
(a)	466
(b)	152
(c)	65
(d)	176
(e)	466
(f)	306
(g)	-

Please see note regarding thruster power and battery rating on page 116.

¹ Performance thrust (kgf x 1.4) equivalent due to increased leverage arm, depth of installation, and short transverse tunnel. Depending on placement and hull shape considerations. Sleipner recommends installing a tunnel thruster instead of the EX-series on planing hulls, as the EX external unit may cause unwanted spray.

Control panels and remote controls

Sleipner offers a unique series of intelligent control panels, an essential part of the thruster system. Choose between our compact touch panel, popular joystick control, intuitive docking control, or the exclusive round control panel.

Why not add a remote control for full mobility onboard? Mix or match. The choice is yours!

Easy installation

- Round cut-out hole (standard size)
- Installs from front
- Pre-fitted O-ring seal
- Multi-voltage 12V/24V

Safety

- Child-safe on/off system
- Power/control light
- Automatic deactivation
- Easy operation

Quality

- Waterproof IP65
- UV safe
- CE approved

Design

- Compact size
- Modern look
- No visible bolts
- Selected models available in black

ON/OFF



Control Panels	8950	8955	8960	8965	8940	8909	8700	PJC211	PJC212	RCS-20 ¹⁾	RC-20 ¹⁾	RC-21 ¹⁾	RC-22 ¹⁾	RC-23 ¹⁾
Description	Touchpanel	Round touchpanel	Joystick panel	Boat switch panel	Dual joystick panel	Docking panel	Touch panel retract	Single joystick PRO	Dual joystick PRO	Remote bow/stern	Remote bow/stern	Remote bow/windl.	Remote windl. x2	Remote bow x2/windl.x2
Height (mm)	70	Ø86.5	70	Ø86.5	120	120	70	141	141	95	95	95	95	95
Width (mm)	70		70		70	70	70	83	83	48	48	48	48	48
Thruster signal	On/Off	On/Off	On/Off	On/Off	On/Off	On/Off	S-Link™ CAN-bus	S-Link™ CAN-bus	S-Link™ CAN-bus	S-Link™ CAN-bus	On/Off	On/Off	On/Off	On/Off
Multi-voltage	Yes	Yes	Yes	Yes	Yes	Yes	Yes	Yes	Yes	Yes	Yes	Yes	Yes	Yes
Child safety	Yes	Yes	Yes	Yes	Yes	Yes	Yes	Yes	Yes	Yes	Yes	Yes	Yes	Yes
For PRO DC Speed Control	-	-	-	-	-	-	-	Yes	Yes	Yes (On/Off only)	-	-	-	-
Item Code Grey	8950 G	8955 G	8960 G	8965	8940 G	8909 C	8700							
Item Code Black			8960 S		8940 S			PJC211	PJC212	RCS-20E/RCS-20U	RC-20E/RC-20U	RC-21E/RC-21U	RC-22E/RC-22U	RC-23E/RC-23U

S-LINK™



The remote receiver accepts up to four independent transmitters.

PJC211 single and PJC212 dual joystick for PRO™ variable speed control

- For PRO™ thruster control with S-Link™
- Fingertip control with purpose-designed joysticks
- Hold function enables to set and leave the level of thrust
- System setup via wizard
- Diagnostics via panel/computer interface
- Built-in alarm buzzer
- Connector for external alarm buzzer
- Backlit LCD with instant feedback:
 - System status and diagnostics
 - Indication of power and direction of thrust
 - Interactive multi-language menus

RC-2 remote controls

All models operate in the 868Mhz band with a new communication protocol to withstand external interference better. The RCR-2E receiver is compatible with four- and five-lead wire cabling for Sleipner thruster and windlass models. The 8-channel remote RCT-23E operates a dual thruster and a dual windlass configuration. Kits come ready paired from the factory. Extra transmitters are available.

- Two-way communication – audiovisual warning for communication error and low thruster voltage
- External antenna solution for better reception and easier remote placement of the antenna (extension cable available)
- Energy-efficient transmitter, only one battery needed
- Dedicated version for thrusters using S-Link™. 8730 interface is not required

1) Please use E type remotes for EU and U type remotes for North America.

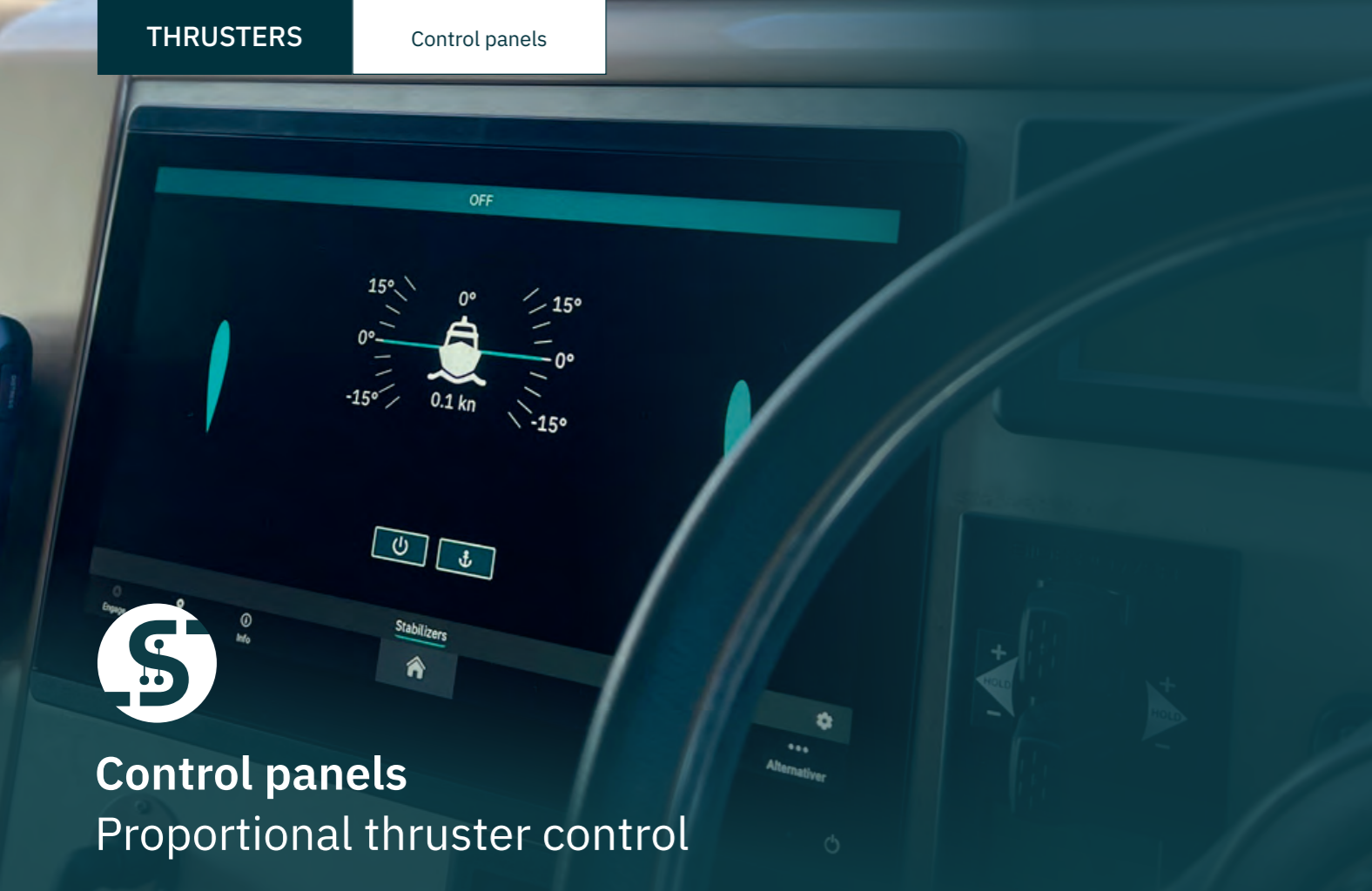

Control panels

Proportional thruster control

PJC2 series

Single or dual joystick with integrated LCD display

- Fingertip control with purpose-designed joysticks
- Hold function enables to set and leave the level of thrust
- Compact design
- Backlit LCD with instant feedback:
 - System status and diagnostics
 - Indication of power and direction of thrust
 - Interactive multi-language menus
- S-Link™ CAN-bus communication
- Built-in alarm buzzer
- Connector for external alarm buzzer
- Plug & Play cables, waterproof and compact connectors
- Supports all Sleipner retractable thrusters
- Supports Vector Fins™ on/off control



Control panel	PJC211	PJC212	PJC221	PJC222
Control panel DNV Design Approved*	N/A	N/A	N/A	N/A
For thruster type	DC/AC	DC/AC	DC/AC/HYD	DC/AC/HYD
Display	Integrated	Integrated	Integrated	Integrated
Height (mm)	141	141	141	141
Width (mm)	83	83	83	83
S-Link™ CAN-Bus	Yes	Yes	Yes	Yes
Multi-voltage	Yes	Yes	Yes	Yes
Child safety	Yes	Yes	No	No
Stop function	No	No	Yes	Yes
Thruster operation	Single	Dual	Single	Dual
Joystick type	Spring, hold-button	Spring, hold-button	Spring, hold-button	Spring, hold-button

*Only available for thruster models with DNV approved gear house

S-Link Display Interface

The S-Link™ Display Interface (SDI-1) activates a Sleipner app on Multi-Functional Displays (MFD). The app enables monitoring and configuration of thruster and stabilizer systems:



- Activate stabilizers and adjust gain
- Monitor thruster operation and status
- Observe and clear active alarms

Works with compatible MFDs from Raymarine, Garmin, Simrad, B&G, and Lowrance. Please consult MFD manufacturers for information on compatible models before purchase.

SDI-1 connects easily to the S-Link™ bus with an S-Link™ spur cable and has a standard RJ45 Ethernet port for connection to MFDs. Some MFDs require a special Ethernet adapter cable. One SDI-1 can interface with multiple MFDs on the same network.



The supplied power cable must power SDI-1. At least one Sleipner control panel must be installed to configure thruster and stabilizer systems.

PJC4 series

Single or dual joystick with stand-alone color LCD display. The bright 3,5" daylight touch screen with an intuitive interface offers an easy day-to-day operation.

- Back-lit touch color LCD with instant feedback:
 - System status and diagnostics
 - Indication of power and direction of thrust
 - Interactive multi-language menus
- IPX7 water ingress rated control panel
- Flush or top mount control panel (HxW: 149x112mm)
- Built-in Wi-Fi module
- S-Link™ CAN-bus communication
- Built-in alarm buzzer
- Plug & Play cables, waterproof and compact connectors
- Dedicated connector for IO signals
- Supports various joystick designs

DNV design approved product variant for all available joystick types

- Power supply fault monitoring
- Display of propeller RPM
- Gearleg low oil level monitoring
- Select station, command transfer between multiple operator stations



TP-35



The PJC4 package consists of joystick of choice and TP-35 control panel.



PJC421-PVREL	PJC422-PVREL	PJC421-LE90	PJC422-LE90	PJC421-LF90X	PJC422-LF90X	PJC421-LF90	PJC422-LF90
PJC421-PVREL-DNV	PJC422-PVREL-DNV	PJC421-LE90-DNV	PJC422-LE90-DNV	PJC421-LF90X-DNV	PJC422-LF90X-DNV	PJC421-LF90-DNV	PJC422-LF90-DNV
DC/AC/HYD	DC/AC/HYD	DC/AC/HYD	DC/AC/HYD	DC/AC/HYD	DC/AC/HYD	DC/AC/HYD	DC/AC/HYD
Stand-alone	Stand-alone	Stand-alone	Stand-alone	Stand-alone	Stand-alone	Stand-alone	Stand-alone
123,4	206,0	96,0	96,0	96,0	96,0	96,0	96,0
105,5	106,0	96,0	96,0	96,0	96,0	96,0	96,0
Yes	Yes	Yes	Yes	Yes	Yes	Yes	Yes
Yes	Yes	Yes	Yes	Yes	Yes	Yes	Yes
No	No	No	No	No	No	No	No
Yes	Yes	Yes	Yes	Yes	Yes	Yes	Yes
Single	Dual	Single	Dual	Single	Dual	Single	Dual
Spring, twist detent	Spring, twist detent	Detent	Detent	Detent	Detent	Detent	Detent

The S-Link™ system

S-Link™ is a CAN-bus based control system with full intelligent communication between all units in the system, much like a computer network. It is used for all retract thrusters and all PRO™ version thrusters with the DC speed control system.

S-Link™ system example:

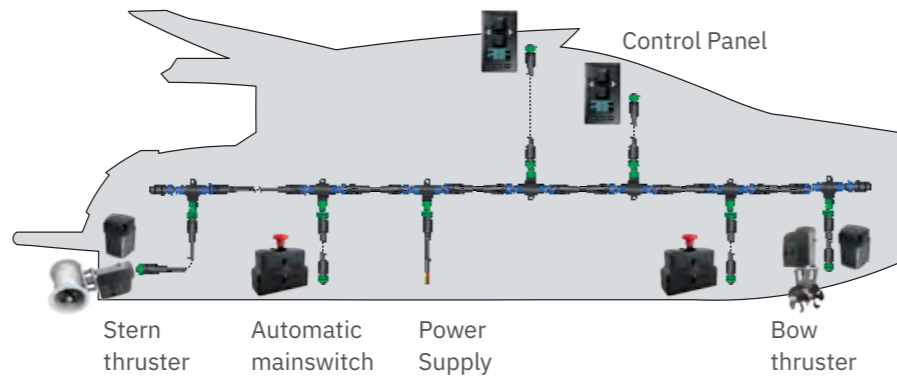

Advantages

- Round, compact and waterproof plugs with unique keying and color coding to avoid faulty hookup
- Unlimited number of commands or information transfer on a single cable
- User feedback to panel
- Intelligent troubleshooting

S-Link™ system for boats with two control positions and two DC proportional thrusters.

Depending on the boat's construction, there might be several different ways to route the S-Link™ backbone. Find the most practical way to implement the backbone and remember that the S-Link™ equipment does not need to be connected in a specific order.

Item code	Description	Parts
6 1320-xx	Backbone cable	6 pcs
6 1321-xx	Spur cable	6 pcs
6 1326	T connector	7 pcs
6 1328	Power cable	1 pc
6 1327	End terminator	2 pcs

S-Link™ cable components



Backbone cables

Forms the main "loop" around the boat.

Item code:

- 6 1320-xxM (xx=length)
- 6 1320-0.2M (0.2m)
- 6 1320-2M (2.0m)
- 6 1320-4M (4.0m)
- 6 1320-7M (7.0m)
- 6 1320-10M (10.0m)
- 6 1320-15M (15.0m)
- 6 1320-20M (20.0m)



Spur cables

Must be used to connect all parts to the backbone cable (one for each component, no exceptions), recommended to be as short as practically possible.

Item code:

- 6 1321-xxM (xx=length)
- 6 1321-0.4M (0.4m)
- 6 1321-1M (1.0m)
- 6 1321-3M (3.0m)
- 6 1321-5M (5.0m)



Power cable

Must be one in each system, length 2.5m

Item code: 6 1328



End terminator

Must be one in each end of the backbone "loop".

Item code: 6 1327



S-Link™ 4-Port T-connector

Allows four spur cable connections in the same device for a more tidy installation with fewer parts. Two sealing caps included for protection.

Item code: 6 1403



Backbone extender

Connects two backbone cables to extend length.

Item code: 6 1322



T connector

Must be one for each spur, including power cable.

Item code: 6 1326

Accessories S-Link™ system



PRO™ upgrade kit

To upgrade a standard on/off thruster to a PRO™ with variable speed control, you need a PPC Power Control Unit and an upgrade kit for the internal wiring loom. Note that sealed units such as IP and SX thrusters must be upgraded by an authorized Sleipner dealer.



Automatic main switch for S-Link™

The most user-friendly and safe installation is provided with an automatic main switch/fuse. The main power to the thruster is conveniently controlled by the Sleipner control panel. Added safety is provided by the panel's auto-off and the thruster's overheat sensor, also controlling the main switch. Compact design with flexible mounting options on wall or bulkhead, plug-and-go wiring, heavy terminals allowing double cables.



S-Link™ Interface

S-Link™ interface to connect footswitch, control panel and radio remote to the S-Link™ system (foot switch, panel and remote not included). Multivoltage 12/24V.



Gateway

The GW-1 gateway is used to interface NMEA2000 devices and Sleipner's S-Link™ system. The gateway can also be used to interface NMEA 0183 compliant GPS products, enabling S-Link™ products to receive GPS time and position data. Manufacturer can apply for access to parts of Sleipner's S-Link™ protocol, allowing 3rd party products to monitor and control Sleipner's S-Link™ thrusters and stabilizer systems.



S-Link Display Interface

The S-Link™ Display Interface (SDI-1) activates a Sleipner app on Multi-Functional Displays (MFD). The app enables monitoring and configuration of thruster and stabilizer systems.



External Signal Interface

The ESI-1 External Signal Interface is used to interface digital IO signals and Sleipner's S-Link™ system. Two analog 4-20mA inputs offer proportional control of S-Link™ compliant bow and stern thrusters. Digital IOs are available for control and feedback signals.



Foot switch

Foot switch kit suitable for 8730 S-Link™ interface. Kit contains 2 switches with covers to protect from unwanted operation. (Cables from switches to 8730 S-Link™ interface not included)

PPC Unit	Compatible with
PPC520	SE25/30/40/50/60 12V SE30-130 24V
PPC820	all models except 48V
PPC840	48V models

Wiring	Compatible with
8 1997	SR80/100
8 1998	SE50/100/120/210/240/250/ 285/300
8 1999	SE25/30/40/60/80/130/150/170

Main Switch	12V	24V
HxWxD (mm)	175x205x140	
Item code	897712	897724

S-Link™ Interface	
H (mm)	45
W (mm)	80
D (mm)	145
Item code bow thruster	8730 B
Item code stern thruster	8730 S

GW-1	
H (mm)	26
W (mm)	50
D (mm)	127

SDI-1	
H (mm)	84
W (mm)	118
D (mm)	54

ESI-1	
H (mm)	156
W (mm)	212
D (mm)	62

Foot Switch	
Diameter (mm)	105
Item code (kit w/ 2 pcs)	8751

SX35/50 series accessories



SX extension Block

For stern mount, available in 10 mm and 50 mm.

- Polyurethan spacer allows for easier installation in proximity to stepped and concave surfaces on the transom
- Spacer functions as galvanic isolation for metal hulls

Item code
EXT-SX35/50-10MM
EXT-SX35/50-50MM



COWLS

- Made of reinforced UV resistant composite material
- Easy installation and retrofit
- Remove cavitation on shallow installations (more thrust, less noise)
- Guide thrust away from flaps or stern drive
- Either preassembled from factory or as retrofit kit.

Item code COWL-SX35/50



Grid safety kit

- Hydrodynamic shape to reduce resistance
- Removable for cleaning and propeller service
- Either preassembled from factory or as retrofit kit
- Made of reinforced UV-resistant composite material

Item code GRID-SX35/50

EX series accessories



Basic installation kit

With two mounting bolts, complete with sealing kit (for EX compact)

Item code 50151



Installation kit

With streamline rubber adapter, complete with sealing kit (not for EX compact).

Item code 50152



GRP Adapter

For bow installation on V-shaped hulls.

Item code 50155



Mooring protector

Made of stainless steel for EX-series motor housing, including fixing kit.

Item code 50154

AC components

AC Thrusters are delivered as a complete ready to install kit.

- PDC301 drive controller
- Variable Frequency Drive (VFD)
- Gearleg with propellers and bracket
- Flexible coupling
- AC motor
- EMC Filter

Each AC thruster system is configured according to the specific working conditions and specifications. No further setup of the VFD is required. The PDC301 is configured from the PJC control panel.

The S-Link™ control system ensures fast and trouble-free installation, and gives you the unique option to combine hydraulic and AC thrusters in a single control environment.

All with variable speed control.

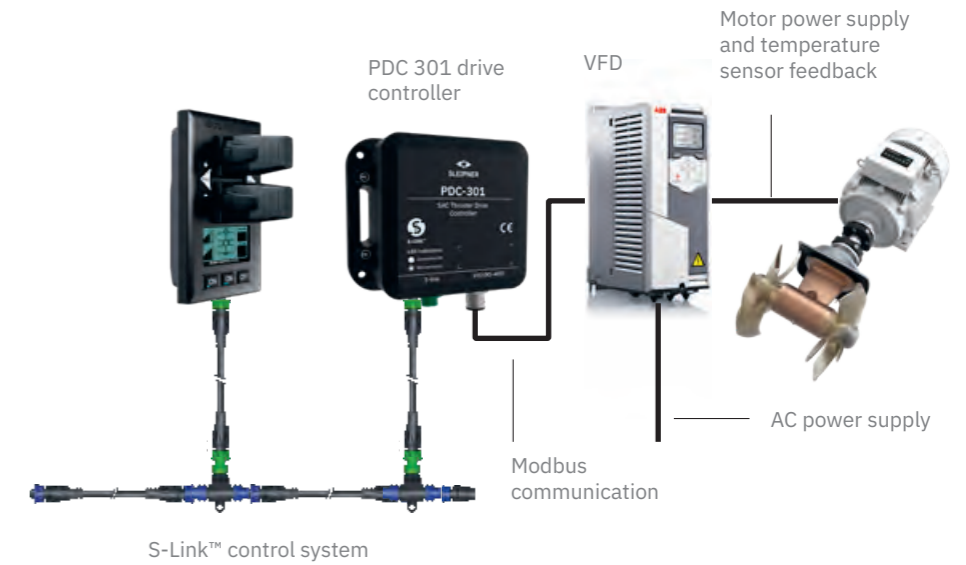

PDC 301 drive controller

- Communication with VFD by Modbus connection
- Included 3-wire cable for connection to VFD Modbus terminals
- Monitoring and diagnostics
- Firmware upgrade through S-Link™ programmer

Variable frequency drive (VFD)

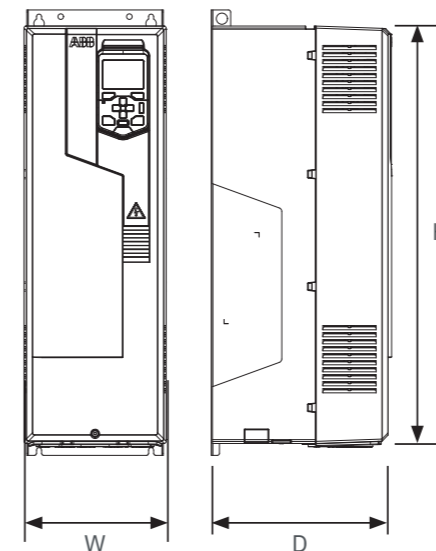

VFD protection: IP21
IP55 on request

VFD	Thruster model	VFD model	Weight kg	D mm	W mm	H mm
SAC240	SAC240/250-C-2-x ²	ACS580-01-047A-2	11,8	228	203	454
	SAC240/250-C-4-x ²	ACS580-01-033A-4	11,8	228	203	454
SAC320	SAC320/300-C-2-x ²	ACS580-01-076A-2	19	258	203	600
	SAC320/300-C-4-x ²	ACS580-01-046A-4	11,8	228	203	454
SAC360	SAC360/300-C-2-x ²	ACS580-01-115A-2	28,3	295	203	732
	SAC360/300-C-4-x ²	ACS580-01-073A-4	19	258	203	636
SAC400	SAC400/300-C-2-x ²	ACS580-01-115A-2	28,3	295	203	732
	SAC400/300-C-4-x ²	ACS580-01-073A-4	19	258	203	636
SAC450	SAC450/386-C-2-x ²	ACS580-01-115A-2	28,3	295	203	732
	SAC450/386-C-4-x ²	ACS580-01-062A-4	19	258	203	600
SAC520	SAC520/386-I-2-x ²	ACS580-01-144A-2	42,4	369	252	727
	SAC520/386-I-4-x ²	ACS580-01-089A-4	28,3	295	203	732
	SAC520/386-C-2-x ²	ACS580-01-144A-2	42,4	369	252	727
	SAC520/386-C-4-x ²	ACS580-01-089A-4	28,3	295	203	732
SAC700	SAC700/412-C-2-x ²	ACS580-01-171A-2	54	370	284	880
	SAC700/412-C-4-x ²	ACS580-01-106A-4	28,3	295	203	732
SAC750	SAC750/513-I-4-x ²	ACS580-01-089A-4	28,3	295	203	732
SAC900	SAC900/513-I-4-x ²	ACS580-01-106A-4	28,3	295	203	732
SAC1100	SAC1100/513-I-4-x ²	ACS580-01-145A-4	42,4	369	252	727
	SAC1100/513-C-4-x ²	ACS580-01-145A-4	54	370	284	880
SAC1300	SAC1300/610-I-4-x ²	ACS580-01-169A-4	54	370	284	880
SAC1400	SAC1400/610-I-4-x ²	ACS580-01-169A-4	54	370	284	880

Accessories DC thrusters

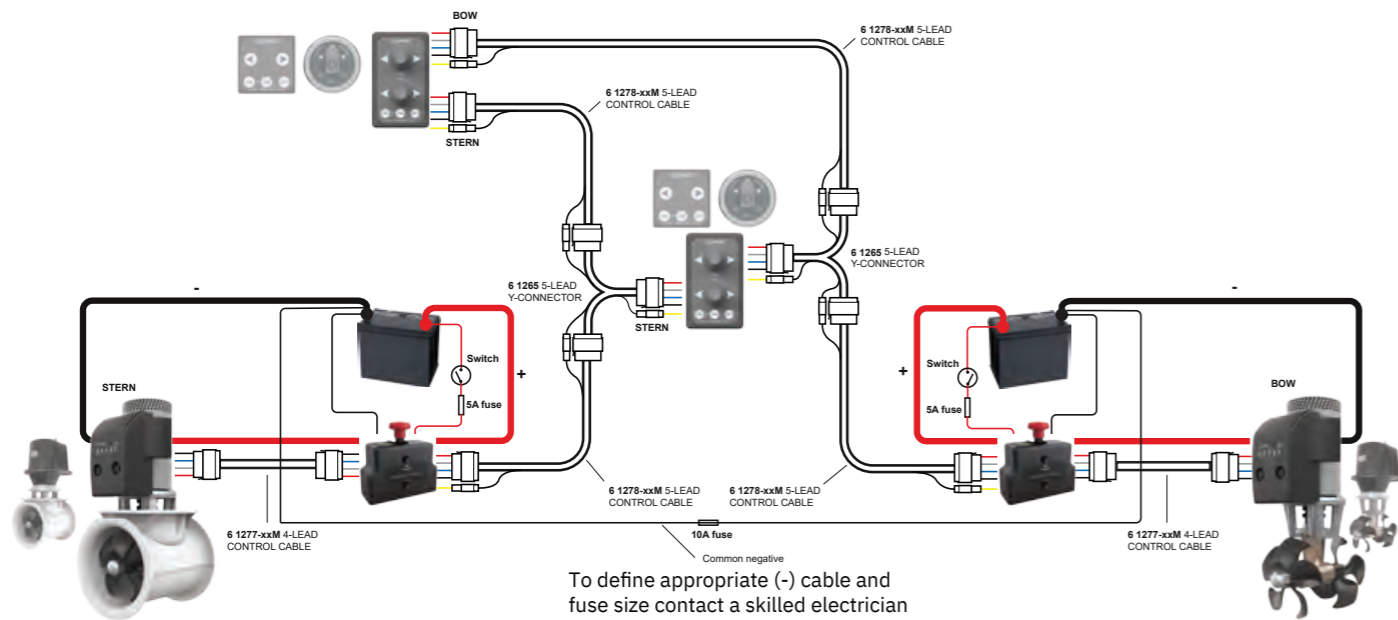

A complete thruster system

A complete system consists of several parts. Besides the thruster unit(s) and tunnel(s) - bow, stern, or both, you will need control cables, main switches (automatic or manual), fuse and fuse holder, control panel(s), and main power cables. Even a radio remote is a normal part of a thruster system today.



Serial-parallel switch box

Automatic switch box enabling installation of 24V thrusters in boats with a 12V system. With an additional 12V battery (not included), you supply 24V for the thruster's operation, while all batteries are charged by your regular 12V system when the thruster is not running.

Switch box	SE 120/130/150/170
HxWxD (mm)	285 x 265 x 110
Item code	10112A
Switch box	SE200/250
HxWxD (mm)	285 x 265 x 110
Item code	15112A



Automatic Main Switch

The most user-friendly and safe installation is provided with an automatic main switch. The main power to the thruster is conveniently controlled by the Sleipner control panel. Added safety is provided by the panel's auto-off and the thruster's overheat sensor, also controlling the main switch. Compact design with flexible mounting options on wall or bulkhead, Plug & Play wiring, heavy terminals allowing double cables. Fuse not included.

Main Switch	12V	24V
HxWxD (mm)	175x205x140	
Item code	897612	897624

The electric motors used on the thrusters require a good electric power supply to operate and achieve the desired power safely. Both the main power cable sizes and the available battery capacity are essential.



Fuse holder / Fuses

Sleipner manufactures fuse holders engineered to minimize voltage drop and heating while saving space. Made for ANL type fuses in high current applications, they accept double cables with heavy terminals. The fuse holder is also available with a protective cover. We supply ANL fuses in different sizes to match all of our thrusters.

Item code	Fuse	For thruster 12V	For thruster 24V
ANL80	80A		EX75S · EX55C
ANL100	100A	EX35S · EX25C	EX95S · EX70C
ANL125	150A	EX55S · EX110D	EX40C · EX180D
ANL150	150A	SE20 · SE25 · SE30 · SX35	SE/SX50 · SE60
ANL250	250A	SE40	SE/SR/SRL/SRV/SX80
ANL325	325A	SE/SX50 · SE60	SE/SR/SRL/SRV/SX100 · SE120 · SE/SRL/SRV130 · SE/SRV300
ANL400	400A	SE/SR/SRL/SRV/SX80	SE/SRL/SRV170
ANL500	500A	SE/SR/SRL/SRV/SX100 · SE/SRL/SRV130	SE150 · SE/SRV210 · SE/SRV250
ANLHOLD		Fuseholder for all ANL type fuses	
ANLHOLD-C		Fuseholder including clear cover	



Plug & Play control cables

Ensure that the complete installation meets the Sleipner quality standard and utilize our Plug & Play wiring system using original control looms. They are available in many lengths, and Y-connectors tie multiple control positions together. Color-coded to match the wiring diagrams with high-quality connectors to ensure correct installation. This cable is for all thruster models besides the PRO™ series and retractable thrusters.

When using the automatic main switch in your thruster system, you need the 5-lead cable between the control panel and auto-switch. The extra lead will actively control the switch and thereby the main power to the thruster, adding further safety. Please see schematics on top left page.

Description	Item code 4-lead	For thruster 12V
Control cable 4 meter	6 1277-04M	6 1278-04M
Control cable 7 meter	6 1277-07M	6 1278-07M
Control cable 9 meter	6 1277-09M	6 1278-09M
Control cable 12 meter	6 1277-12M	6 1278-12M
Control cable 15 meter	6 1277-15M	6 1278-15M
Control cable 18 meter	6 1277-18M	6 1278-18M
Control cable 22 meter	6 1277-22M	6 1278-22M
Y-connector for multiple control panels	6 1274	

Components of a complete thruster system

- Thruster(s) – bow thruster, stern thruster or both
- Tunnel(s) – for bow, stern or both
- Control cables
- Main switch (automatic or manual)
- Fuse and fuse holder
- Control panel(s)
- Main power cables
- Radio remote

SLEIPNER

Windlasses

An anchor windlass makes boating easier. With the controlled free-fall system, all you have to do is let the anchor go and focus on taking the boat smoothly to the shore.

Anchor with ease

Anchoring in unknown waters or in-between other boats can be a boater's worst fear. With a windlass installed, you can lower your shoulders and take your time when anchoring and docking your boat.

Automatic free fall

Sleipner windlass systems allow for the fastest way to anchor your boat with an integrated free-fall release system. Anchoring your vessel fast allows for precise anchoring positioning, opposing powering down where your boat will drift while waiting to secure the lines.

Parking-mode

Sleipner windlass systems allow you to set retract resting points to ease in securing your anchor during a wind-up operation. This can leave the anchor to be set just below the waterline to clean the anchor to the vessel before lifting to its final resting position.

Built on the legacy of Scandinavian boating

Sleipner's windlasses are intended for mounting on the boat's stern, which is unique for Scandinavian boating. We often moor with the bow facing the shore as our coastlines contain countless scattered islands.



MIDI



Internal mounting
Leaded line



External mounting
Leaded line







Side mounting
Leaded line



Mounted on deck
Leaded line/chain

MAXI

Product features for lead line

-  AUTOMATIC FREE FALL CONTROL
-  PARKING-MODE
-  PWM CONTROL
-  REMOTE CONTROL (OPTIONAL)

Technical details

Ideal vessel class	Motor boat, Sail boat
Ideal vessel size	<7m / <25ft Midi. <21m / <70ft Maxi
Power	12/24V
Motor output	600/1000/1500 Watt
Placement	Internal/external/deck/side
Rec. anchor weight	7,5–30 kg
For	line/chain

Choosing the right anchor windlass for your boat

When choosing an anchor windlass, you must consider your boat's size and design, mounting and placement of the windlass, and anticipated anchoring conditions, including pulling power and type of ground tackle.

Windlass sizing

Which windlass size you should go for is mainly determined by your boat's size and weight. Additionally, the windlass's placement and mounting will give you reliable insight into which model to select.

When driving a car in first gear, it is easy to get up to speed quickly. This also applies to your anchoring equipment. At higher speeds, it requires more power from the windlass's gear housing and gipsy.

- For 12-volt vessels up to 3 tons, you need an electric motor of around 600 watts.
- For boats over 3 tons, you need an electric motor of about 1000 watts.
- Larger 24-volt vessels usually end up with an electric motor of around 1500 watts.

Placement and Mounting

Sleipner windlasses are constructed for mounting on the boat's stern.

Internal	External	On Deck	Side-Mounting
Midi 203	Maxi 31	Maxi 32	Maxi 34G
Maxi 40	Maxi 32	Maxi 32C	
Maxi 43	Maxi 32C	Maxi 34D	
Maxi 44			

Power Supply

When the windlass is mounted on the stern, the boat's main battery is usually not far away. If you make sure that the engine is always running when you are using the windlass (except for minor adjustments), this won't pose a problem for the battery's starting capacity.

Still, we advise connecting the windlass to your secondary battery or thruster battery, if applicable.

Windlass pulling power

A windlass's maximum load capacity should be four times its usual working load, meaning the anchor's combined weight, rode, and hardware.

Lead line or chain?

The weight of the lead line or chain is essential as it helps you achieve softer anchoring. With a correct weighted line or chain, it takes longer to stretch when the boat moves, and you avoid strong jerks.

Windlass with lead line

In Scandinavia, most people choose lead lines as they predominantly anchor at the stern. A lead line is lighter than a chain but still has a high dead weight and good durability. All Sleipner windlasses with lead line come with automatic free fall and are equipped with a parking function, including soft start and double auto-stop function.

Windlass with chain

A chain is by far the most common worldwide. A chain has high durability and weighs a lot, which is an advantage on bigger boats, but a disadvantage on smaller boats due to the increased weight concentration at the boat's back. Chains are extended to the desired length without features such as automatic free fall. This is because the chain's weight would drag the entire length of the chain to the bottom. In practice, this means that it takes longer to prepare anchoring with a chain than with a lead line.

A complete windlass system

Sleipner windlass systems are customized to boat type, design and your needs as a boat owner. You can learn more about the different components in a complete windlass system below.

Windlass

Midi 203 is suitable for boats up to 25 feet and the Maxi-series is suitable for boats up to 70 feet.

Anchor

Boats up to 2 tons	5 kg anchor
Boats up to 3 tons	7,5 kg anchor
Boats up to 4 tons	10 kg anchor
Boats up to 8 tons	15 kg anchor
Boats up to 15 tons	20 kg anchor
Boats up to 20 tons	30 kg anchor

Anchor Rode

With the help of our large selection of anchor rodes and hull penetrations, Sleipner windlasses are easily adaptable to most boats.

Control Box

The windlass controller monitors the operating time and power consumption of the anchor windlass while protecting the electric motor.

Control Panel

Waterproof control panel with child lock makes anchoring safe and easy.

Remote Control (Optional)

You can operate the windlass from anywhere in the boat and even a remote location with a remote controller.

When the boat is anchored up at the stern with the bow facing shore, you can pull the boat out from land remotely, reducing the risk of waves from passing boats causing your boat's bow to pound against shore.

Fuse

150A for Midi windlasses and 200A for Maxi windlasses.

Electrical Cables

- 4-lead cables.
- Battery cable kit.

Anchor Swivel (Recommended)

A swivel is a rotating shackle between the line and the anchor, which prevents the anchor from spinning and twisting the line/chain and at the same time holds the anchor in place in the anchor roll. Recommended for all installations.

Anchor Safety Chain (Recommended)

The anchor must always be fastened with a safety chain to secure the anchor to the boat while driving. The safety chain is attached to the boat or anchor roll and usually has a shackle that makes it easy to connect the anchor when parked in the anchor roll. Recommended in all installations.



Technical Details

Midi anchor windlasses

The MIDI is a compact free-fall anchor windlass suitable for boats up to 3 tons. Only available with lead rope.

Maxi anchor windlasses

MAXI is a series of anchor windlasses in various sizes with free-fall, suitable for boats over 3 tons. Some models are available with chain.

Product features

Automatic free-fall function

The automatic free-fall function allows the release of the windlass anchor line in a controlled manner, maintaining a slight resistance ensuring the line doesn't rush to the bottom. Therefore, it releases as much line as required for the water depth and length for the mooring.

Parking mode

Parking mode provides another user-friendly feature. With an end-stop sensor and brass wire ring in the line, the anchor automatically stops at the water line or 'rinsing position'. This allows the anchor to clean away any mud, seagrass or other sea bed materials before carefully settling the anchor in its final secure position.

Accessories

Accessories are available in several variants to enable tailored solutions for various boat types. The anchor windlass requires an MCU control box, circuit breaker, and control panel and other accessories such as hull penetration, anchor line, and anchor rode.

Internal	External	On Deck	Side-Mounting
Midi 203	Maxi 31	Maxi 32	Maxi 34G
Maxi 40	Maxi 32	Maxi 32C	
Maxi 43	Maxi 32C	Maxi 34D	
Maxi 44			



Maxi 43 and Maxi 44

Anchor windlass for internal mounting, suitable for boats up to 70 feet. Maxi 43 is a powerful windlass with features such as automatic free fall and parking mode.

The mounting bracket can rotate 360 degrees, which means that you have numerous mounting options: against the transom, front bulkhead or hanging horizontally below deck. The electric motor and rope guide is also rotatable, simplifying the installation considerably by enabling mounting on surfaces with a different angle in relation to the transom. **Deciding to mount on the starboard or port side** could depend on space.

Maxi 44



With the Maxi 43 and 44, you can decide which side you want to install the line wheel. We recommend having the line wheel facing towards the middle of your vessel instead of out towards the hull. This will allow easier access for service and maintenance. However, this depends on your boat's construction and your preferences.

- The Maxi 43 has the line wheel fitted starboard, ideal for mounting on the port side.
- The Maxi 44 has the line wheel fitted port ideal for mounting on the starboard side.



Maxi 43



Midi 203

Anchor windlass for internal mounting, suitable for boats up to 25 feet/3 tons. Midi 203 is a compact and flexible windlass with features such as automatic free fall and parking mode.

The mounting bracket can rotate 360 degrees, which means that you have numerous mounting options: against the transom, front bulkhead or hanging horizontally below deck. The electric motor and rope guide is also rotatable, simplifying the installation considerably by enabling mounting on surfaces with a different angle in relation to the transom.



Midi 203



Maxi 31

Anchor windlass for external mounting on the transom. Maxi 31 is a windlass with features such as automatic free fall and parking mode. A classic and proven model that is very common on boats with limited space.



Maxi 40

Anchor windlass for internal mounting on the transom, suitable for boats up to 70 feet. Maxi 40 is built into a plastic cover and has features such as automatic free fall and parking mode.



Maxi 32

Anchor windlass for external mounting on deck or anchor box, suitable for boats up to 70 feet. Maxi 32 is a windlass with features such as automatic free fall and parking mode.

A classic proven model which is very common on boats with a stern cabin and bathing platform where space is limited.



Maxi 32C

Anchor windlass with chain for external mounting on deck or anchor box, suitable for boats up to 70 feet. 32C is a classic proven model which is very common on boats with a stern cabin and bathing platform where space is limited.

The anchor line is driven in and out but can also be released with the included handle and adjustable slip brake. Maxi 32C is compatible with chain 8mm DIN 766 and 6.5mm Norwegian standard.



Maxi 34-D

Anchor windlass designed for external deck mounting in various locations at the aft, bow, anchor or bathing platform (with access to internal space) of the boat. Fully equipped with functions such as automatic free fall and parking mode.

Commonly the Maxi 34D is installed at the bow of the vessel, however, in larger classes, it can be installed on the bathing platform provided that space allows for the rope to drop downwards.



Maxi 34-G

Anchor windlass for external mounting/ side-mounting suitable for boats up to 70 feet with a built-in bathing platform or extension. Maxi 34G is a windlass with features such as automatic free fall and parking mode.

Maxi 34-3G is for mounting the port side, with the electric motor inside the vessel and the line wheel facing the bathing platform starboard.

Maxi 34-4G is for mounting on the starboard side with the electric motor on the inside and the line wheel facing the bathing platform port.

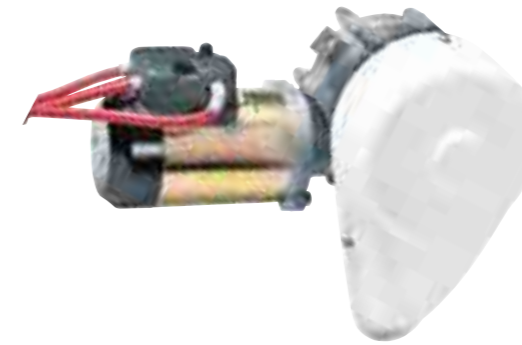

Modell	Midi 203
Mounting	Internal
Motor output	600 W
Weight (kg)	12
Power Requirement (V)	12 V
Pulling power (max)	200 kg
Pull speed	20 m / min vid 30 kg load
Ideal Vessel Size	< 25 fot / 7,6 m
Auto stop function	Yes
Recommended fuse	150 Amp - 12V
Recommended anchor/ weight	7,5 - 15 kg
Line	12 mm Anchor line, leaded
Item code 12V	36-12106

Modell	Maxi 43 & 44
Mounting	Internal
Motor output 12 V	1000 W
Motor output 24 V	1500 W
Weight (kg)	20 Kg
Power Requirement (V)	12 V / 24 V
Pulling power (max) 12 V	500 kg
Pulling power (max) 24 V	850 kg
Pull speed	20–25 m / min
Ideal Vessel Size	< 15.2 m - 1000 W < 21.3 m - 1500 W
Auto stop function	Yes
Recommended fuse	150 Amp
Rec. min. battery capacity 12 V	100 Ah
Rec. min. battery capacity 24 V	60 Ah
Recommended anchor/ weight	10–26 kg - 1000 W 10–30 kg - 1500 W
Line	14–16 mm Anchor line, leaded
Item code 12V starboard	43-12110 (line gypsy starboard)
Item code 12V port	44-12110 (line gypsy port)
Item code 24V starboard	43-24115 (line gypsy starboard)
Item code 24V port	44-24115 (line gypsy port)

Modell	Maxi 34-G	Maxi 34-D
Mounting	Side-mounting	On deck
Motor output 12 V	1000 W	1000 W
Motor output 24 V	1500 W	1500 W
Weight (kg)	20 kg	20 kg
Power Requirement (V)	12 V / 24 V	12 V / 24 V
Pulling power (max) 12 V	500 kg	500 kg
Pulling power (max) 24 V	850 kg	850 kg
Pull speed	20–25 m / min	20–25 m / min
Ideal Vessel Size	< 15.2 m - 1000 W < 21.3 m - 1500 W	< 15.2 m - 1000 W < 21.3 m - 1500 W
Auto stop function	Yes	Yes
Recommended fuse	200 Amp	200 Amp
Rec. min. battery capacity 12V	100 Ah	100 Ah
Rec. min. battery capacity 24V	60 Ah	60 Ah
Recommended anchor/ weight	10–26 kg - 1000 W 10–30 kg - 1500 W	10–26 kg - 1000 W 10–30 kg - 1500 W
Line	14–16 mm Anchor line, leaded	14–16 mm Anchor line, leaded
Item code 12V starboard	-	-
Item code 24V	-	-
Item code 12V starboard	34-3G-12110 (line gypsy starboard)	-
Item code 12V port	34-4G-12110 (line gypsy port)	34-D-12110
Item code 24V starboard	34-3G-24115 (line gypsy starboard)	-
Item code 24V port	34-4G-24115 (line gypsy port)	34-D-24115

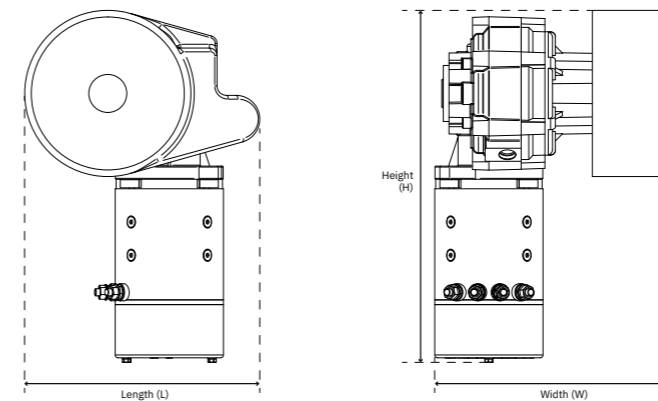
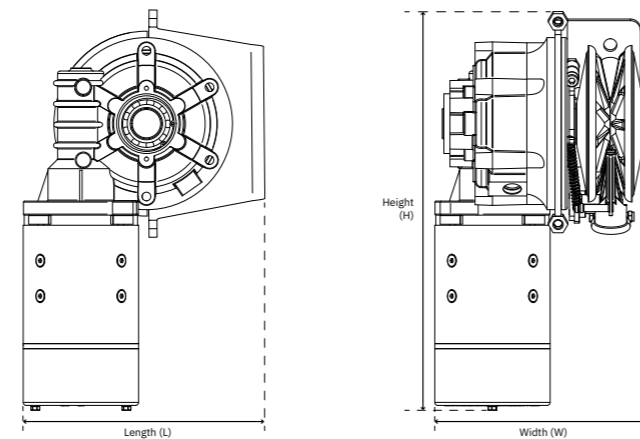
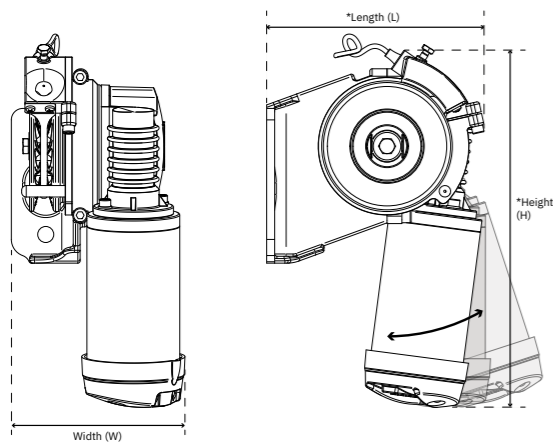

	Midi 203
(H) Height (mm)	330
(L) Length (mm)	180
(W) Width (mm)	150
(a)	85
(b)	29
(c)	14
(d)	25
(e)	70
(f)	30
(g)	13
(h)	32.5
(i)	14

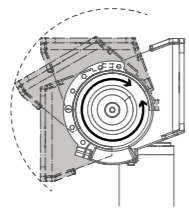

* The Windlass system is designed to allow customizable orientation of the motor or support bracket. Offering for more flexibility to install the windlass system in the space you have available.

mm	Maxi 43 & 44
(H) Height (mm)	238
(L) Length (mm)	393
(W) Width (mm)	219

	Maxi 34-G	Maxi 34-D
(H) Height	370mm	250mm
(L) Length	283mm	283mm
(W) Width	255mm	250mm



Modell	Maxi 31	Maxi 40
Mounting	External	internal
Motor output 12 V	1000 W	1000 W
Motor output 24 V	1500 W	1500 W
Weight (kg)	20 kg	20 kg
Power Requirement (V)	12 V / 24 V	12 V / 24 V
Pulling power (max) 12 V	500 kg	500 kg
Pulling power (max) 24 V	850 k	850 kg
Pull speed	20–25 m / min	20–25 m / min
Ideal Vessel Size	< 15.2 m - 1000 W < 21.3 m - 1500 W	< 15.2 m - 1000 W < 21.3 m - 1500 W
Auto stop function	Yes	Yes
Recommended fuse	200 Amp	200 Amp
Rec. min. battery capacity 12V	100 Ah	100 Ah
Rec. min. battery capacity 24V	60 Ah	60 Ah
Recommended anchor/ weight	10–26 kg - 1000 W 10–30 kg - 1500 W	10–26 kg - 1000 W 10–30 kg - 1500 W
Line	14–16 mm Anchor line, leaded	14–16 mm Anchor line, leaded
Item code 12V	31-12110	40-12110
Item code 24V	31-24115	40-24115

Modell	Maxi 32	Maxi 32C
Mounting	External	External
Motor output 12 V	1000 W	1000 W
Motor output 24 V	1500 W	1500 W
Weight (kg)	20 kg	20 kg
Power Requirement (V)	12 V / 24 V	12 V / 24 V
Pulling power (max) 12 V	500 kg	650 kg
Pulling power (max) 24 V	850 kg	1000 kg
Pull speed	20–25 m / min	20–25 m / min
Ideal Vessel Size	< 15.2 m - 1000 W < 21.3 m - 1500 W	< 15.2 m - 1000 W < 21.3 m - 1500 W
Auto stop function	Yes	No
Recommended fuse	200 Amp	200 Amp
Rec. min. battery capacity	100 Ah 60 Ah	100 Ah 60 Ah
Recommended anchor/ weight	10–26 kg - 1000 W 10–30 kg - 1500 W	10–26 kg - 1000 W 10–30 kg - 1500 W
Line / chain	14–16 mm Anchor line, leaded	8 mm DIN 766 / 6,5 mm
Item code 12V	32-12110	32-C-12110
Item code 24V	32-24115	32-C-24115

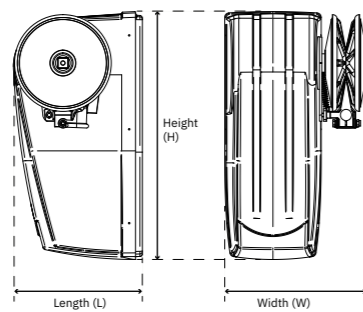

Position	Maxi 31	Maxi 40
(H) Height (mm)	200	200
(L) Length (mm)	396	396
(W) Width (mm)	230	230

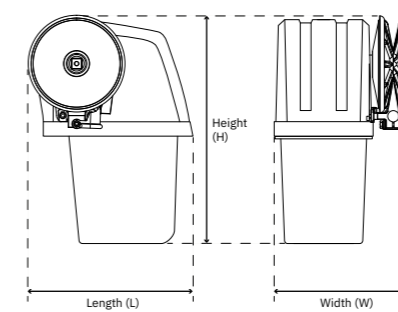

Position (mm)	Maxi 32	Maxi 32C
(H) Height	200mm	200mm
(L) Length	255mm	255mm
(W) Width	230mm	230mm



Control panels and remote controls

A waterproof and child-proof control panel makes anchoring safe and easy.

With an additional radio remote, you can operate the windlass from anywhere in the boat and even remotely. When the boat is anchored up with the bow facing shore, you can have the windlass pull the boat out from land, reducing the risks of waves from passing boats causing your boat's bow to pound against shore.

Remote control features:

- Two way communication - audiovisual warning for communication error and low thruster voltage
- External antenna solution for better reception and easier remote placement of the antenna (Extension cable available)
- Maintains operating time from earlier models with two batteries

Easy installation

- Round cut-out hole (standard size)
- Installs from front
- Pre-fitted O-ring seal
- Multi-voltage 12V/24V

Safety

- Child-safe on/off system
- Power/control light
- Automatic deactivation
- Easy operation

Quality

- Waterproof IP65
- UV safe
- CE approved

Design

- Compact size
- Modern look
- No visible bolts
- Selected models available in black



Electronic control unit for windlasses

The controller from Sleipner monitors the windlass' operating time and power consumption. These data are used to protect the overloading the motor and secure normal windlass operation. In addition, the box regulates motor speed, maximum pull power providing a lower speed and less power when the anchor gets pulled into parking mode. It's easy to mount and compatible with Sleipner's remote controls, allowing you to operate the windlass from wherever you choose.

Item code 150800

Features and benefits

- Programmable windlass type (Midi/Maxi/Maxi Chain)
- Automatic detection of 12V or 24V system
- Fully insulated circuit board with fixed bolts for easy connection
- PVM speed control (soft start and reduced speed after the first end-stop or by double click "up")
- Voltage compensated (the traction decreases after the first end-stop mode)
- Easy connection of both series and permanent magnet motors
- Protected against the incorrect connection of +/- connection (polarity protection)
- LEDs for to indicate operation status and errors. (ie. endstop detection, low voltage etc.)
- Engine protection against overheating and overload
- The control unit has a temperature sensor
- Safety relays that breaks in the event of a short circuit
- Quick-connect terminals for panel and end stop sensor
- Fixed points for the supply cables

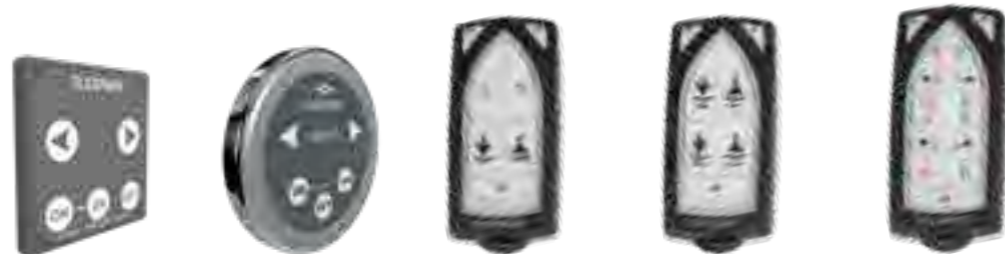

Control Panels	86-08950	86-08955	RC-21	RC-22	RC-23
Description	Touchpanel	Round touchpanel	Remote bow/windlass	Remote windlass x2	Remote bow x2/windlassx2
H (mm)	70	Ø86.5	95	95	95
W (mm)	70		48	48	48
Colour	Grey / Black	Grey / Black	Black	Black	Black
Multi-voltage	Yes	Yes	Yes	Yes	Yes
Child safety	Yes	Yes	Yes	Yes	Yes
Cable length	Sold seperately*	Sold seperately*	-	-	-
No. of windlasses	1	1	1	2	2
Item Code Grey	86-08950	86-08955	-	-	-
Item Code Black	86-08950 S	86-08955 S	RC-21E	RC-22E	RC-23E



Control cable for panel and remote controller, 4-lead

Length	Item code
1,5 meter	6 1277-01,5M
4 meter	6 1277-04M
7 meter	6 1277-04M
9 meter	6 1277-09M
12 meter	6 1277-12M



Circuit breaker for windlass

Circuit breaker	Fuse	Windlass	Windlass
Item code		12 V	24 V
119-00015	150 A	Midi	-
119-00004	200 A	Maxi	Maxi



Item Code 61-30001
Description Pivoting anchor roller, SSL, 350mm

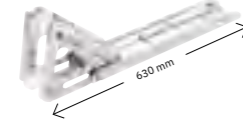

Item Code 61-30002
Description Pivoting anchor roller, SSL, 500mm

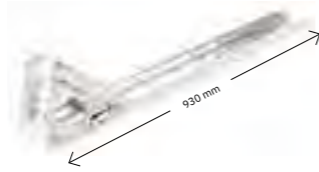

Item Code 61-30003
Description Pivoting anchor roller, SSL, 800mm

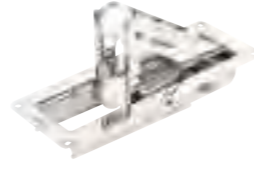

Item Code 61-30004
Description Platform anchor roller, SSL

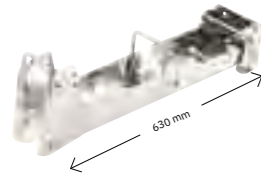

Item Code 61-30005
Description Anchor roller, SSL



Item Code 61-30006
Description Stern anchor roller, SSL, 300mm



Item Code 61-30007
Description Stern anchor roller, SSL, 400mm



Item Code 61-30010
Description Platform anchor roller, SSL



Item Code 65-50001
Description Platform anchor roller, narrow type, SSL, roll w. 45 mm

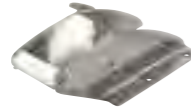

Item Code 65-50002
Description Platform anchor roller, wide type, SSL, roll w. 75 mm



Item Code 60-50000
Description Compact anchor roller, 90° SSL



Item Code 60-65000
Description Compact anchor roller, 45° SSL



Item Code 39-72000
Description Through-hull for windlass chain, SSL



Item Code 39-73000
Description Through-hull anchor line guide, SSL
recommended for MIDI & MAXI



Item Code 39-74000
Description Through-hull anchor line guide, SSL
recommended for MAXI



Item Code 39-75000
Description Through-deck anchor line guide with 1 roller, SSL
recommended for MIDI & MAXI



Item Code 39-76000
Description Through-hull anchor line guide, SSL
recommended for MIDI



Item Code 39-77000
Description Through-hull anchor line guide, swiveling gooseneck
recommended for MIDI & MAXI



Item Code 54-00040
Description D-shackle 9mm, SSL, 5-15kg



Item Code 54-00041
Description D-shackle 12mm, SSL, 20-30kg



Item Code 85-00000
Description Swivel for anchors, SSL, 15-30kg, L=120mm



Item Code 85-00001
Description Swivel for anchors, SSL, 5-15kg, L=100mm



Item Code 12-00212
Description Safety chain for anchors, SSL, L=60cm

All accessories made of stainless steel (SSL).

Pivoting anchor roller

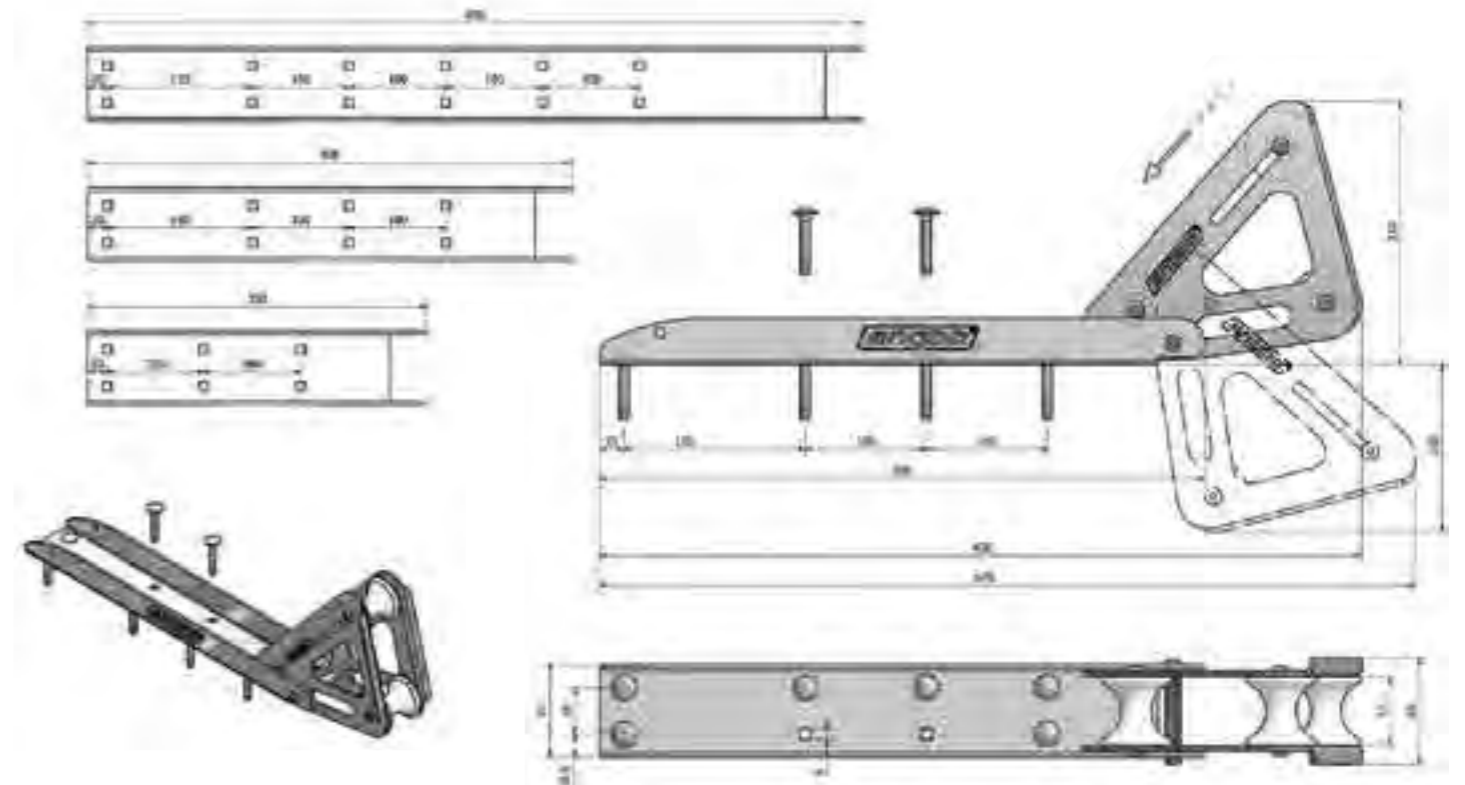

Anchor roller 61-30005

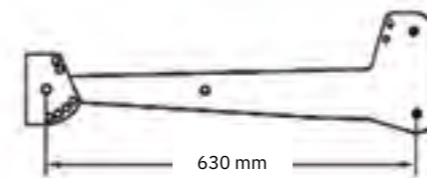

Stern anchor roller 61-30006, 61-30007

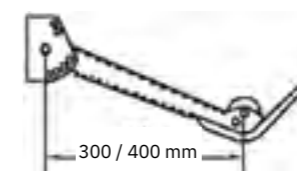

Platform anchor roller



Item code	Description	Length
61-30006	Stern anchor roller	300 mm
61-30007	Stern anchor roller	400 mm

Item code	Model	Length
65-50001	narrow 45 mm	120 mm
65-50002	wide 75 mm	140 mm

61-30010 Platform anchor roller

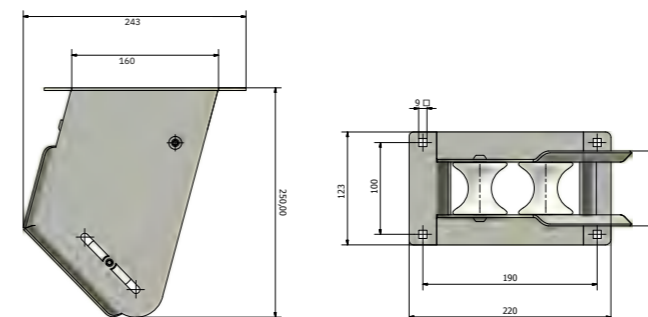

Item code	39-75000	39-77000
Description	Through-hull anchor line guide with 1 roller	Through-hull anchor line guide, swiveling gooseneck
Length	147	136
Width	61	50
Height	66	83

Anchors and lines

Plow anchor

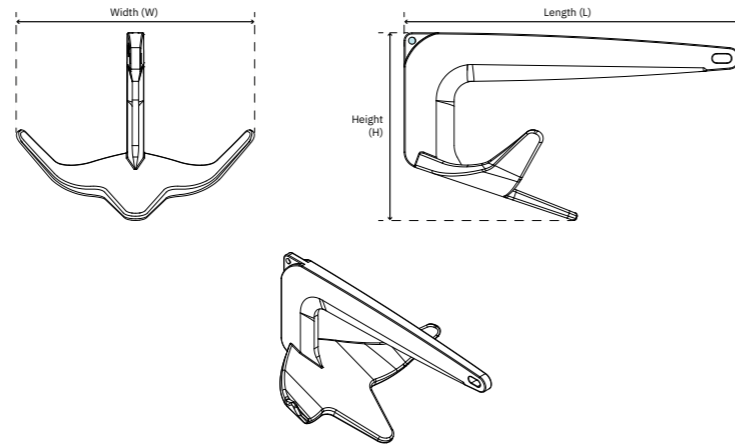

Item code	Weight	Model	Item code	Weight	Model	Measurments (mm)			Max boat weight
Galvanized			Stainless steel (SSL)			H	L	W	
85-81075	7,5 Kg	Galvanized	85-81075	7,5 Kg	SSL	258	520	378	3,5 ton
85-81010	10 Kg	Galvanized	85-81010	10 Kg	SSL	294	585	382	6 ton
85-81015	15 Kg	Galvanized	85-81015	15 Kg	SSL	342	650	423,4	10 ton
85-30020	20 Kg	Galvanized	85-81020	20 Kg	SSL	360	640	503,2	20 ton
85-80030	30 kg	Galvanized	Also available in 30 kg			300	770	577	30 ton

Anchor line



- Art nr på 12mm 50m är 80-10110
- Art nr på 16mm 50m är 80-10120
- Art nr på 16mm 75m är 80-10121
- Art nr på 16mm 100m är 80-10122

Item code	Description	Diameter (mm)	Length (m)	Weight (Kg)	Breaking point (Kg)
80-10109	Anchor line, leaded	12	30	7,9	1600
85-80010	Anchor line, leaded	12	50	11,6	1600
80-10111	Anchor line, leaded	14	50	16,1	2000
80-10120	Anchor line, leaded	16	50	21,7	2400
80-10121	Anchor line, leaded	16	75	32	2400
80-10122	Anchor line, leaded	16	100	43	2400
85-00000	Swivel for anchors, stainless polished steel, L=120 mm				
85-00001	Swivel for anchors, stainless polished steel, L=100 mm				
12-00212	Safety chain for anchors, stainless, 60 cm				
80-20655	Chain for windlass, NS galvanized	6,5	50	-	-
80-20850	Chain for windlass, galvanized	8	50	-	-
80-22655	Chain for windlass, galvanized	6,5	50	-	-
80-22850	Chain for windlass, galvanized	8	50	-	-

Note! For optimal function of the anchor winch, use the original Slepner anchor line.

Mushroom anchor

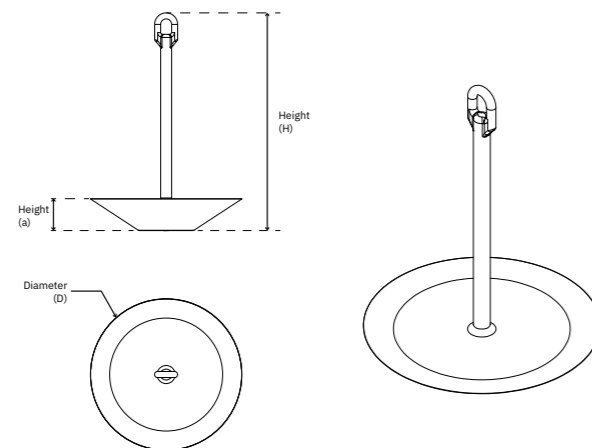

Item code	Weight	Model	Measurments (mm)			Max boat weight
Stainless steel (SSL)			H	D	a	
85-30005	5 Kg	SSL	350	200	42	1 ton
85-30008	8 Kg	SSL	300	230	53	2 ton
85-30010	10 Kg	SSL	360	250	53	3 ton
85-30012	12 Kg	SSL	380	275	60	4ton
85-30020	20 Kg	SSL	485	310	67	8 ton

Maintenance of stainless steel products

Polishing and waxing stainless steel parts protect against stains. Superficial rust stains caused by chemical and electrical contamination in the seawater can be removed with a bit of oil on a cloth.



SLEIPNER

Hydraulic Steering

Sleipner's hydraulic steering systems are perfectly adapted to a wide range of recreational boats. You can easily select the best-suited equipment for your boat's specific needs within a wide range of pumps, cylinders, and accessories made from seawater resistant materials.

Experience the difference in steering comfort

Sleipner's hydraulic steering systems are perfectly adapted to a wide range of recreational boats. You can easily select the best-suited equipment for your boat's specific needs within a wide range of pumps, cylinders, and accessories made from seawater resistant materials.

Cylinders

Sleipner produces its hydraulic cylinders for rudders and water jets in various sizes, making them adaptable to almost any boat. They are available as heavy duty cylinders and standard cylinders.

Steering Pump

Sleipner's steering pumps are a result of intensive R&D and many years of experience in the production of hydraulic steering systems.

Advantages

- Safer and more precise control of your vessel
- An integrated non-return valve helps the rudder maintain its position without holding the steering wheel
- Minor mechanical wear means minimal maintenance and extended product-life
- Best alternative if you want two or more steering positions
- Stable course with minimal use of force



Certification

Heavy Duty Cylinders
DNV type approved

Standard Cylinders
Approved by the Norske Veritas for Recreational Boats.

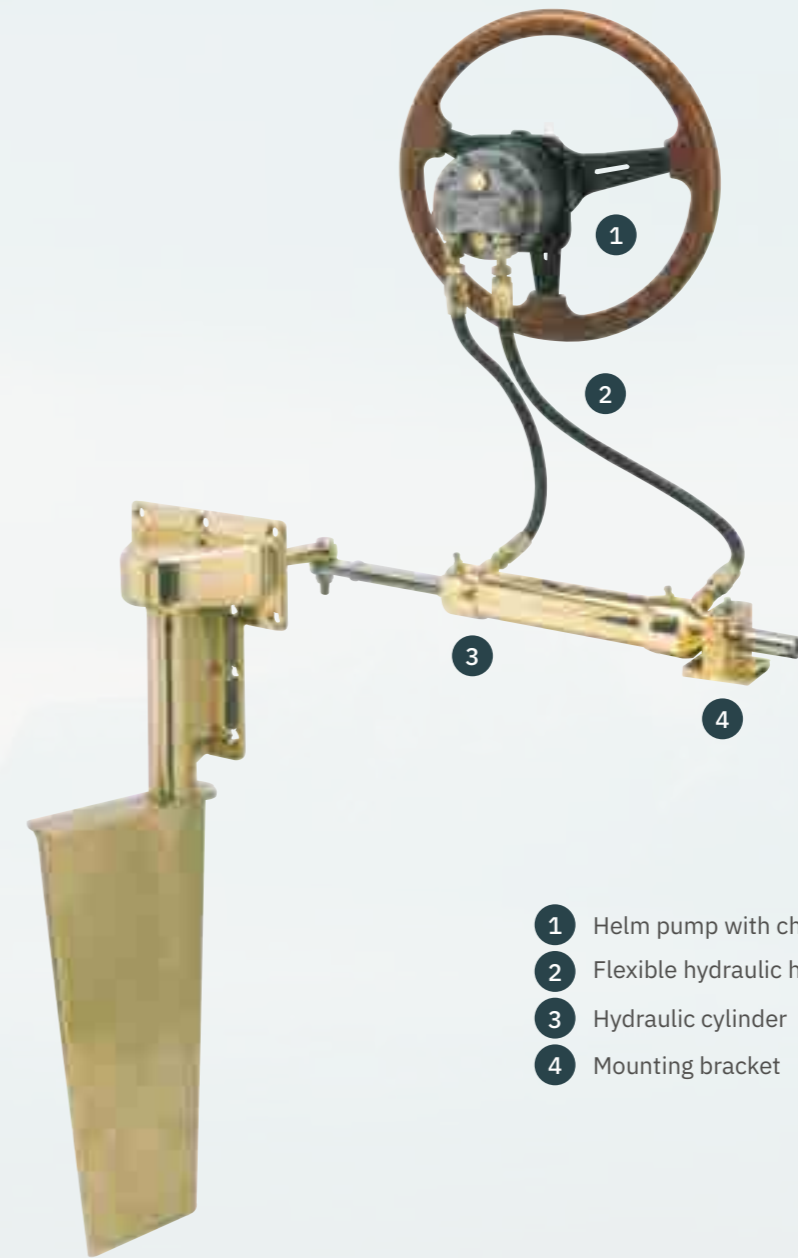

- 1 Helm pump with check valve
- 2 Flexible hydraulic hose
- 3 Hydraulic cylinder
- 4 Mounting bracket

Technical details

Ideal Vessel Class	Commercial vessel, Motor boat, Sail boat
Steering Positions	Multiple
Standard Cylinder	110–565 cm ³ / 50 bar
Heavy duty Cylinder	1111–1187 cm ³ / 70–85 bar
Helm Pumps	26, 35, 43, 70 cm ³
Helm pump installation	Flange, flush, tilt

Hydraulic cylinders

Sleipner's hydraulic cylinders fit a wide range of installations. They are adaptable to most rudders and water jets as long as the rudder torque does not exceed what the cylinder is intended for.

Finding the right cylinder

Rudders

To find the proper steering for boats with rudders, you must calculate the rudder torque. The calculation formula can be found under technical details in the cylinder's product information.

Pump Jets

For water jets and other types of installations, please contact a Sleipner dealer that can assist you.



Heavy Duty Cylinders

Our series of heavy-duty cylinders are designed to deliver maximum performance and reliability for our power steering systems. Still, several of the cylinders are equally suitable with a traditional hydraulic steering pump. Teflon gaskets of the highest quality provide a smooth ride with minimal friction and maintain high pressure.

- Three sets of connection ports allow for installation of an optional shock and by-pass valve
- DNV Type approved

Standard Cylinders

Sleipner's standard cylinders are of very high quality and are in use in thousands of boats. The cylinders are proven and have a very long service life.

- Robust construction in stainless steel and brass
- Long lifetime
- Easy air purging
- Supplied with attachment nipples
- Approved by the Norwegian Veritas for Recreational Boats

Learn more at our blog or at our website.



Hydraulic steering pumps

The steering pump is the heart of a hydraulic steering system. This component decides how much oil to pump through to the system's muscle which is the cylinder.

Sleipner offers three different models for different boats and dashboard designs.

All three models are available in 26 cm³, 35 cm³ and 43 cm³ for adaption to different hydraulic cylinders, or the desire to choose a steering wheel mandrel.

Additionally, we have a more extensive steering pump of 70 cm³, which has 10 pistons. This pump is mainly used together with our largest cylinder, only available as a recessed model.

DNV EN30592

- Axial piston pump with fine-tuned piston angles
- Seven pistons for smooth and precise steering
- Piston in hardened steel
- Stable and rigidly mounted acid-resistant steering shaft with four ball bearings
- Integrated non-return valve
- Large internal oil reservoir
- All parts in corrosion-free materials

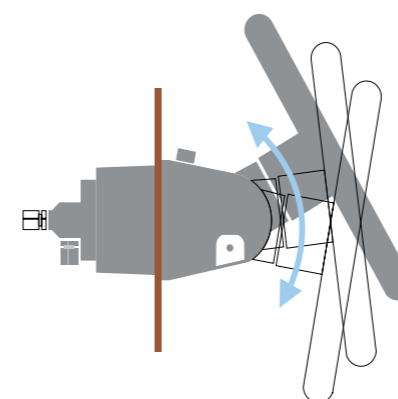

5 positions:
-10°, 0°, 10°, 20°, 30°



Item code: WH28SS
Constructed material: Stainless steel
Diameter: 28 cm



Item code: WH28SORT
Constructed material: Stainless steel/rubber
Diameter: 28 cm



Helm pump with flange



Helm pump with flush mount



Helm pump with tilt

Helm pumps 26–43 ccm

Item number 72061–72069

Helm pumps with flange

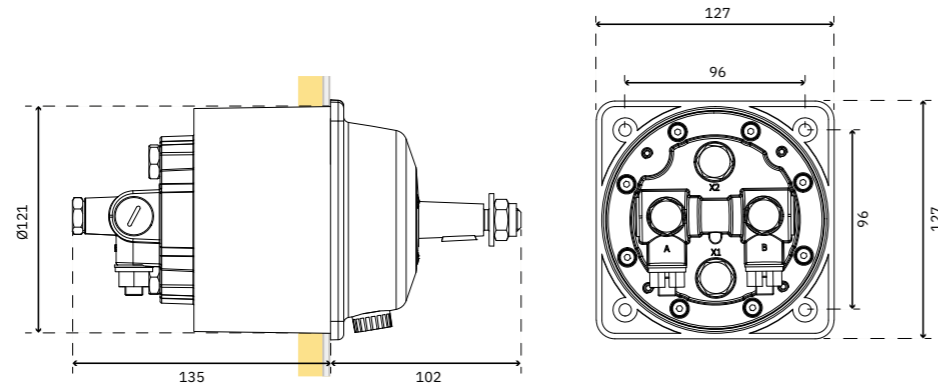

Helm pumps with flange and tilt

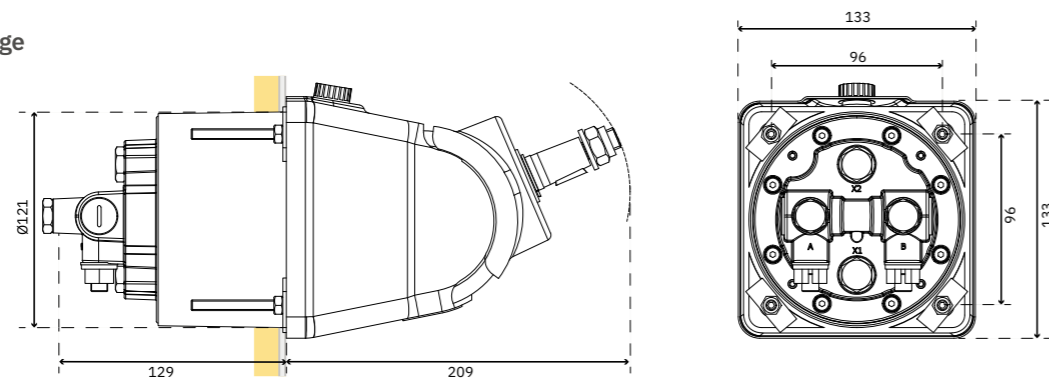

Helm pumps flush mount

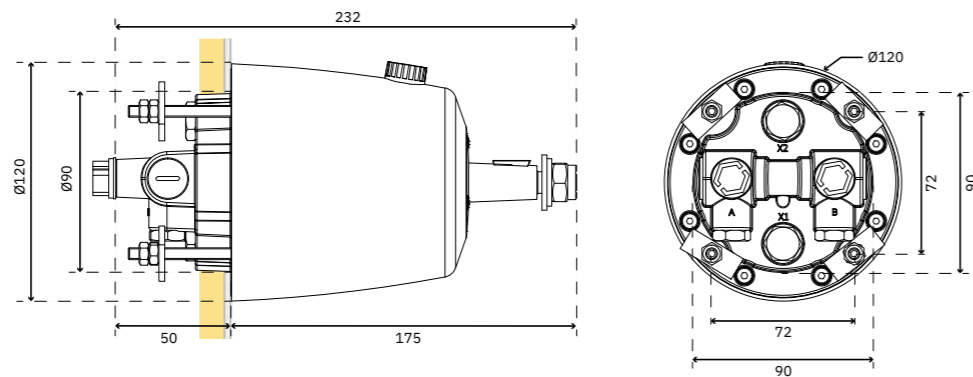

Helm pump 70 ccm

Item number 72070

Helm pumps with flange

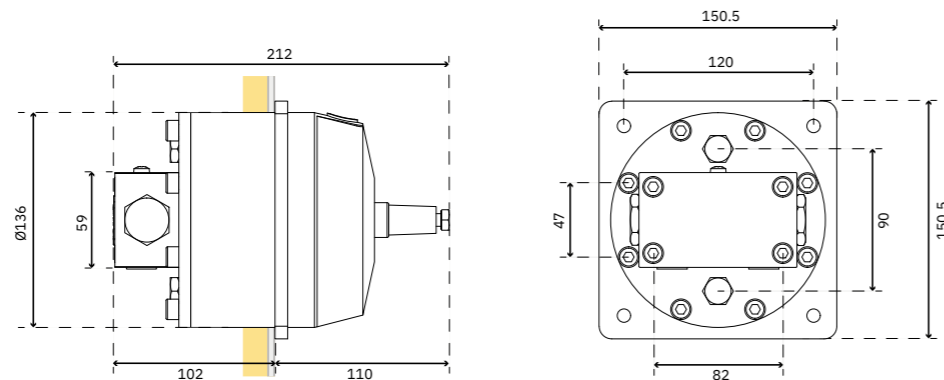

Item code	Port Flange Thread	Helm pump	Port dimensions BSP A/B x1/x2	
72061	26 ccm	with flange	1/4"	1/4"
72062	35 ccm	with flange	1/4"	1/4"
72063	43 ccm	with flange	1/4"	1/4"
72064	26 ccm	with tilt	1/4"	1/4"
72065	35 ccm	with tilt	1/4"	1/4"
72066	43 ccm	with tilt	1/4"	1/4"
72067	26 ccm	flush mount	1/4"	1/4"
72068	35 ccm	flush mount	1/4"	1/4"
72069	43 ccm	flush mount	1/4"	1/4"
72070	70 ccm	with flange	3/8"	1/4"



Hose coupling, 90°



T-coupling



By-pass valve



Hydraulic oil

Meets ISO-VG-15, DIN 51524-3 HVLP specifications.



Hydraulic hose for steering

1 layer steel braided
Inner Ø: 9,5 mm (3/8").
Outer Ø: 12 mm
Meets DNV standard EN 30592



Union fitting

Description	Item code standard	Item code stainless
Union fitting 1/4" BSP x 10 mm	72200	72210
Hose coupling, 10 mm for 3/8" hose	72335	72336
T-coupling for 10 mm	72500	73510
Hose coupling, 90°, 10 mm	72400	72410
Hydraulic hose for steering, 3/8" 1 layer steel braided	72135	
Hyd. hose for steering, PA/11 2004, non pressure ventilation hose	72140	
By-pass valve 10 mm	72600	
By-pass valve 12 mm	72612	
Hydraulic oil for steering, 1 ltr	72750	
Hydraulic oil for steering, 12 pack (12x1 ltr)	72760	
Hydraulic oil for steering, 2,5 ltr	72700	



Rudder tiller arm

Made of coated cast iron, available single or dual, for shafts of 40–80 mm diameter, length 215–345 mm, width 115-180 mm.

Contact us for more details and custom-made products.

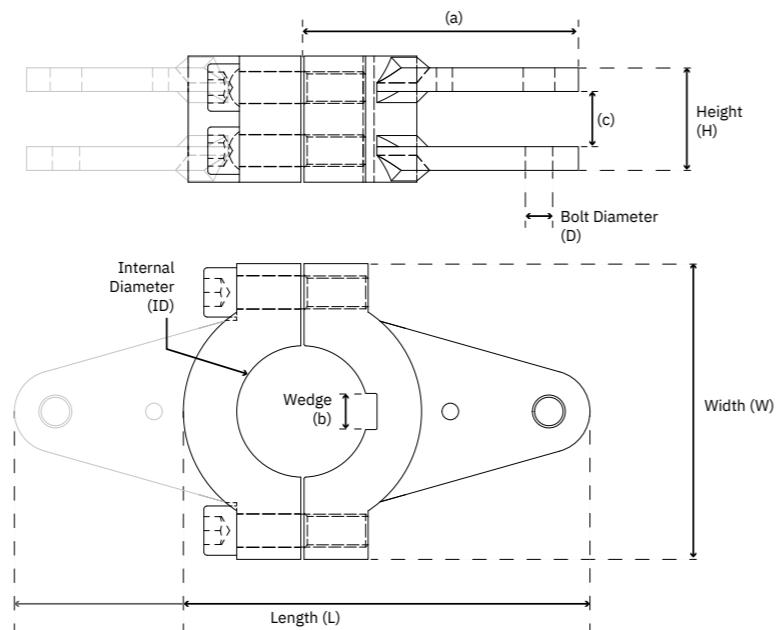

Item code	Material	Description	For shaft ID	Size Group	(H) Height	(L) Length	(W) Width	(D) Bolt dia.	(ID)	(a)	(b)	(c)
72848	Coated cast iron	Single	40	1	55	215	115	14	40	150	14	22
72849	Coated cast iron	Dual	40	1	55	340	115	14	40	150	14	22
72844	Coated cast iron	Single	40	1	55	340	115	16	40	150	14	22
72847	Coated cast iron	Dual	40	1	55	215	115	16	40	150	14	22
72850	Coated cast iron	Single	45	1	55	215	115	14	45	150	14	22
72851	Coated cast iron	Dual	45	1	55	340	115	14	45	150	14	22
72836	Coated cast iron	Single	45	1	55	215	115	16	45	150	14	22
72837	Coated cast iron	Dual	45	1	55	340	115	16	45	150	14	22
72852	Coated cast iron	Single	50	1	55	215	115	14	50	150	14	22
72853	Coated cast iron	Dual	50	1	55	340	115	14	50	150	14	22
72838	Coated cast iron	Single	50	1	55	215	115	16	50	150	14	22
72839	Coated cast iron	Dual	50	1	55	340	115	16	50	150	14	22
72854	Coated cast iron	Single	55	2	64	235	150	16	55	150	18	26
72855	Coated cast iron	Dual	55	2	64	345	150	16	55	150	18	26
72856	Coated cast iron	Single	60	2	64	235	150	16	60	150	18	26
72857	Coated cast iron	Dual	60	2	64	345	150	16	60	150	18	26
72858	Coated cast iron	Single	65	2	64	235	150	16	65	150	18	26
72859	Coated cast iron	Dual	65	2	64	345	150	16	65	150	18	26
72860	Coated cast iron	Single	60	2	64	235	150	20	60	150	18	35

Measurements in mm

Rudder rotations and cylinder pump volum

Item code	26 ccm	35 ccm	43 ccm	70 ccm
71030*	4,2	3,1	-	-
71060	4,8	3,6	-	-
71090	8,3	6,1	5,0	-
71140	-	-	8,0	4,9
71220	-	-	-	8,1

Item code	43 ccm	70 ccm
8032-200-xx	-	12,0
9032-200-xx	-	16,7
8032-305-xx	-	18,5

Recommended

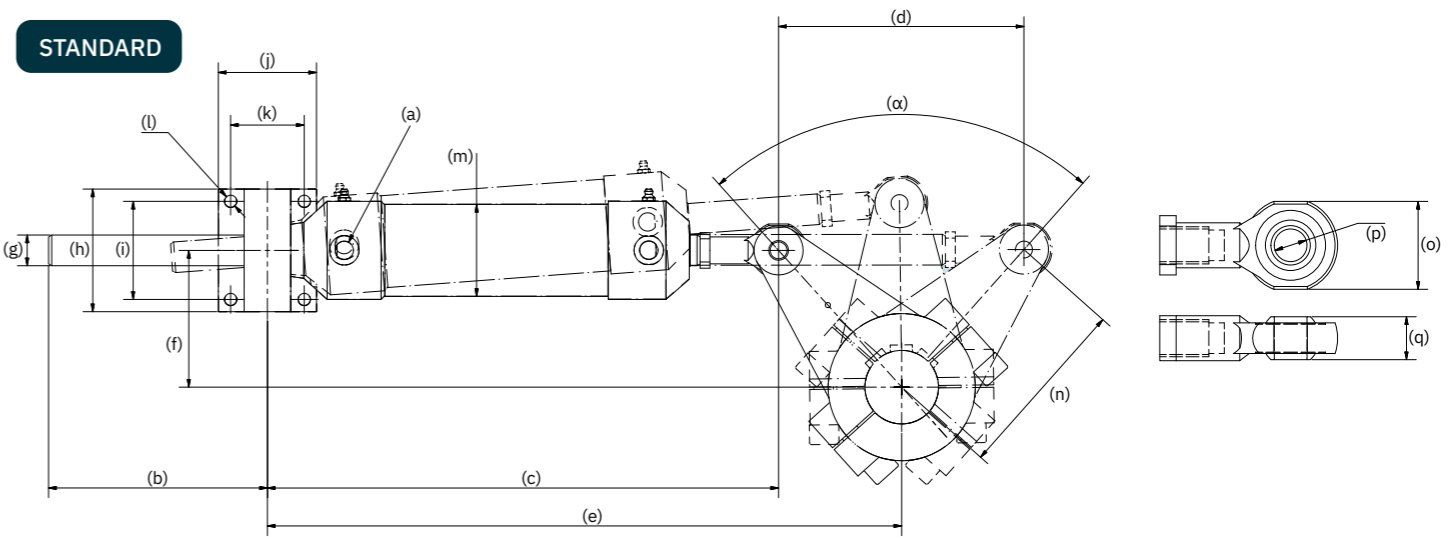

Item code	Volume (ccm)	Mrt 150*	Mrt 180*	Wp*	Recom. hose ID	(a) BSP	(b)	(c)	(d)	(e1)	(e2)	(f1)	(f2)	(g)	(h)	(i)	(j)	(k)	(l)	(m)	(n1)	(n2)	(α)	(o)	(p)	(q)
Standard cylinder																										
71030	110	45	55	50	3/8"	1/4"	151,5	338,5	175	424,5	428,5	122,9	172	16	60	42	50	35	6,5	38	150	180	70	32	12	16
71060	125	45	55	50	3/8"	1/4"	179,5	363,5	200	464	467	111,5	147,5	16	70	52	60	44	8,5	38	150	180	84	32	12	16
71090	215	80	95	50	3/8"	1/4"	178,5	366,5	200	465	470	111,5	147,5	20	70	52	60	44	8,5	48	150	180	84	32	12	16
71140	345	130	155	50	1/2"	1/4"	179	392	200	488,5	491	111,5	147,5	20	80	64	60	44	8,5	57	150	180	84	36	14	19
71220	565	210	250	50	1/2"	3/8"	178,5	416,5	200	520	520	111,5	147,5	25	100	80	80	60	10,5	75	150	180	84	44	16	21
71500	1170	440	500	50	5/8"	M22x1,5	141,5	495,5	200	596	599	111,5	147,5	25	110	86	120	97	10	100	150	180	84	50	20	25

Measurements in mm.

Mrt1: Max rudder torque (kgm) with 150mm tiller arm
Mrt2: Max rudder torque (kgm) with 180mm tiller arm

Wp: Max working pressure in bar
(e1): with 150mm tiller arm
(e2): with 180mm tiller arm

(f1): with 150mm tiller arm
(f2): with 180mm tiller arm
(n1): with 150mm tiller arm
(n2): with 180mm tiller arm

HEAVY DUTY

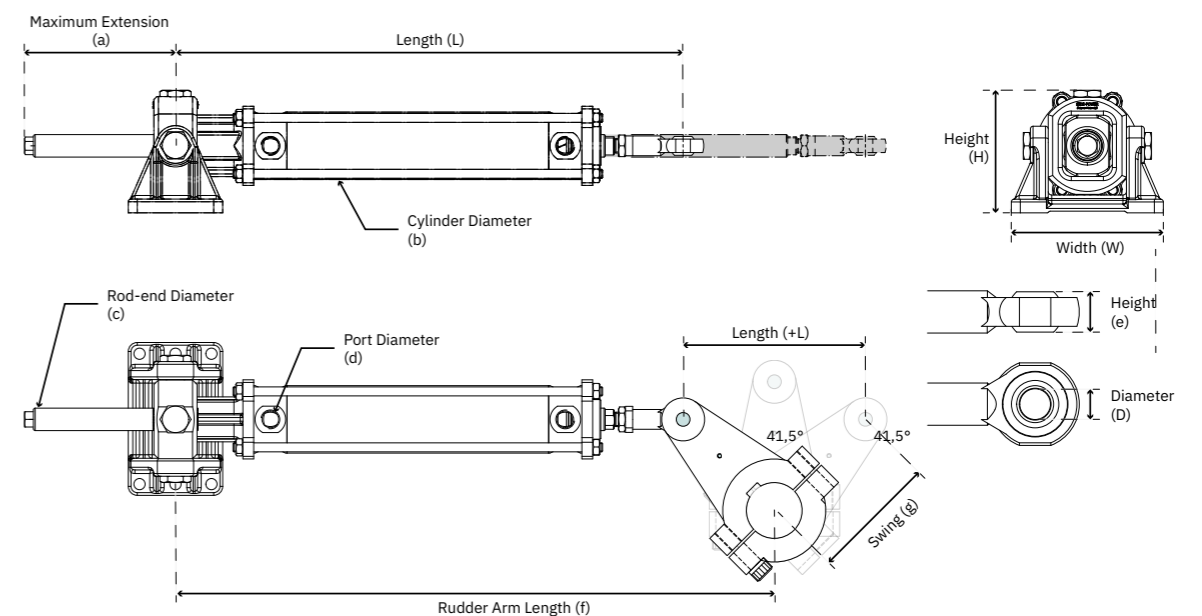

Item code	Volum (ccm)	Max rudder torque (kgm) v/150mm tiller	Working pressure (bar)	Recom. hose ID	Cylinder diam. (b)	Rod diam. (c)	Port dimension (d)	Max Extension (a)	Length (L) (f)	Stroke length (+L) (g)	Diameter (D) (h)	Height (e)		
Heavy duty cylinder														
9032-200-7-60	1111	580	70	1/2"	100	32	1/2"	135	556	656	200	150	20	25
9032-200-7-70**	1111	580	70	1/2"	100	32	1/2"	135	556	656	200	150	20	25
8032-305-9-60	1287	-	85	1/2"	90	32	1/2"	240	679	832	305	-	25	20
8032-305-9-70**	1287	-	85	1/2"	90	32	1/2"	240	679	832	305	-	25	20

Measurements in mm. Contact Sleipner for more information and dimensioning.

**with shock and by-pass valve

We create

world-leading technologies that consistently improve safety and comfort at sea and set the benchmark for the boating of tomorrow.



Worldwide sales and service
www.sleipnergroun.com

Distributor information: