

Installation Guide

For Automatic Main Switch
897612, 897624



SLEIPNER MOTOR AS

P.O. Box 519

N-1612 Fredrikstad

Norway

www.sleipnergroun.com

DOCUMENT ID: 5I96

REVISION: 7

DATE: 2022

LANGUAGE: EN

MI

Contents

Installation Manual

Responsibility of the installer.....	3
General Installation Considerations and Precautions.....	3
Product Measurements	4
Automatic Main Switch (AMS).....	5
Automatic Main Switch (AMS) Installation.....	6
AMS Fuse and Battery Cable Installation and Override Button.....	6
Electrical Installation.....	7
Single Thruster Technical Wiring Diagram	8
Dual Thruster Technical Wiring Diagram	9
Service.....	10
Service and Support.....	11
Product Spare Parts and Additional Resources.....	11
Warranty Statement.....	11

Products

SM901970 | 897612 - Auto-Mainswitch 12V
SM901971 | 897624 - Auto-Mainswitch 24V



Sleipner Motor AS
P.O. Box 519, Arne Svendsensgt. 6-8
N-1612 Fredrikstad, Norway

MC_0020

Failure to follow the considerations and precautions can cause serious injury, damage and will render all warranties given by Sleipner Motor as VOID.

MC_0411

Responsibility of the Installer

MC_0038

The installer must read this document to ensure necessary familiarity with the product before installation.

Instructions in this document cannot be guaranteed to comply with all international and national regulations. It is the responsibility of the installer to follow all applicable international and national regulations when installing Sleipner products.

The recommendations given in this document are guidelines ONLY, and Sleipner strongly recommends that advice is obtained from a person familiar with the particular vessel and applicable regulations.

This document contains general installation instructions intended to support experienced installers. If you are not skilled in this type of work, please contact professional installers for assistance.

If required by local regulation, electrical work must be done by a licensed professional.

Appropriate health and safety procedures must be followed during installation.

Faulty installation of Sleipner products will render all warranties given by Sleipner Motor AS.

General Installation Considerations and Precautions Guidelines

MC_0440

For Sleipner automatic main switch

MC_0273

- Install the automatic main switch as close to the battery(ies) as possible.
- Do not connect the Sleipner automatic main switch with other products than appropriate original Sleipner control panels or other SLEipner control devices. **(NB: Sleipner products are specifically designed with a separate fifth control cable for the automatic main switch.)**
- The automatic main switch must be installed so that it keeps dry at all times.
- The automatic main switch can NOT be fitted in spaces requiring Ignition protected equipment.
- Ensure to use the correct fuse for the main switch depending on the thruster model installed.

IMPORTANT

This manual is to be used in addition to the regular installation manual for the Sleipner thruster. This manual is intended for professionals only.

Measurement code	Measurement description	AMS	
		mm	inch
H	Height	194.3	7.6
L	Length	205	8.1
W	Width	79	3.11
+ W	Width including fasteners	90	3.54
(a)	Attachment hole from the top	51.5	2.03
(b)	Attachment hole from the bottom	92.8	3.65
(c)	Attachment hole from the side	37.5	1.5
(d)	Distance between attachment hole	121.8	4.8
(e)	Attachment hole from the side	45.7	1.8

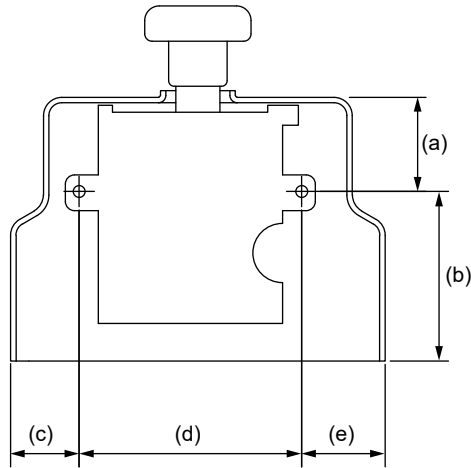
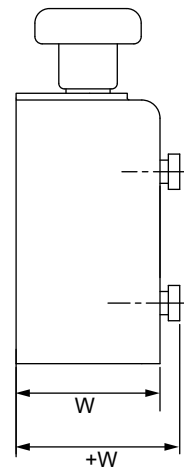
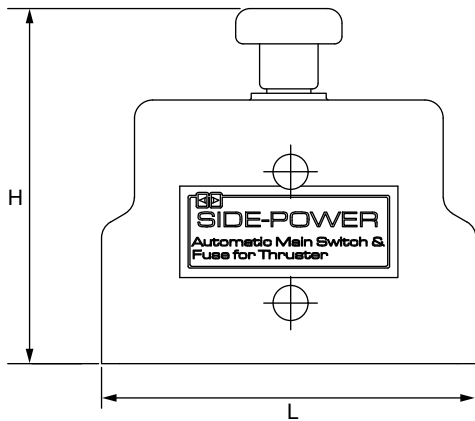

MG_0321

Automatic Main Switch (AMS)

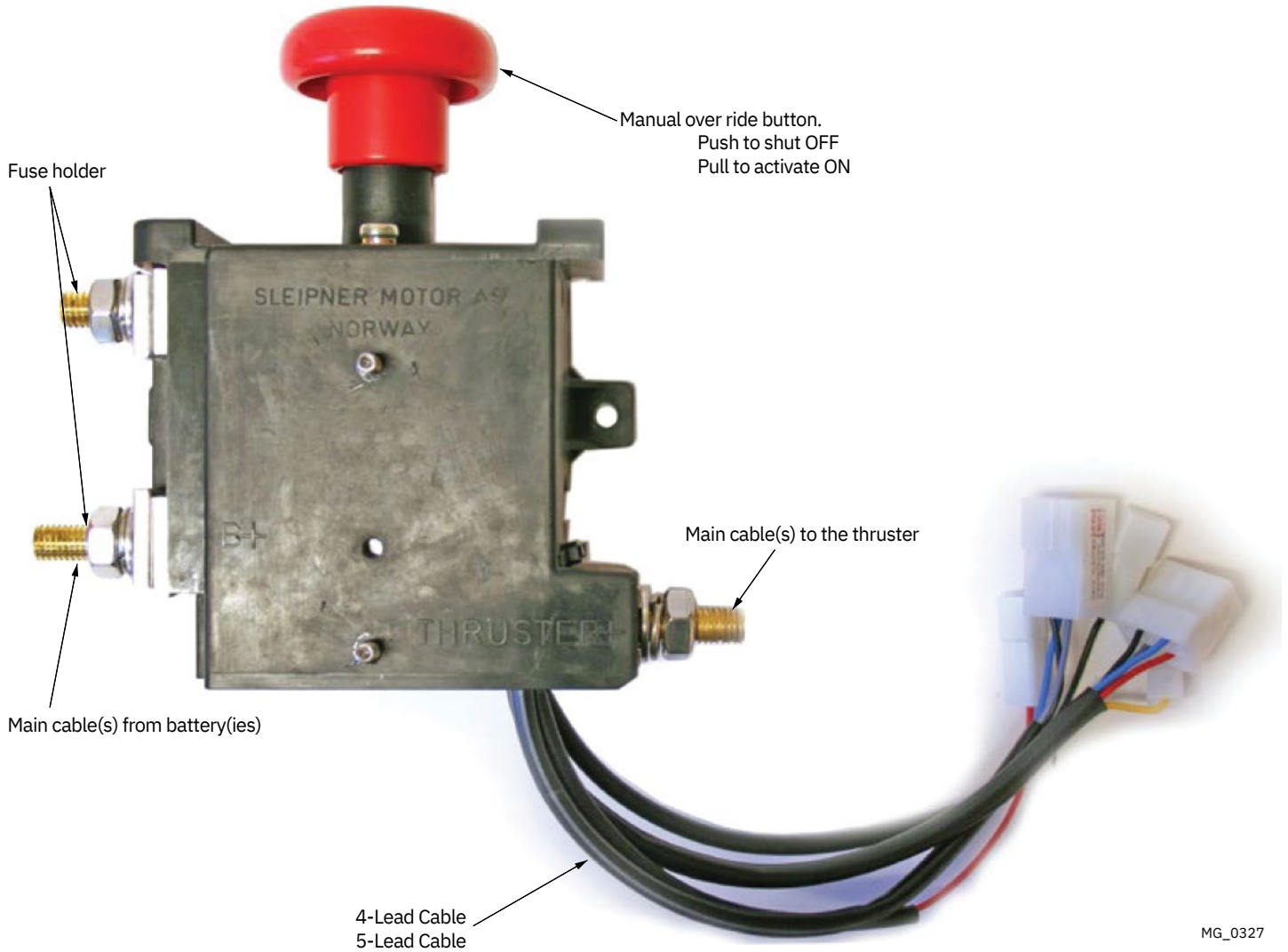

Automatic Main Switch (AMS) Installation

MC_0275

Installing the Automatic Main Switch (AMS).

1. Remove the cover screws and cover from the Automatic Main Switch.
2. Find an appropriate location to install the AMS to allow quick and easy access to the shut-off button and Keeping power cable lengths to a minimum. Attach the AMS using the two fastening holes on each side.

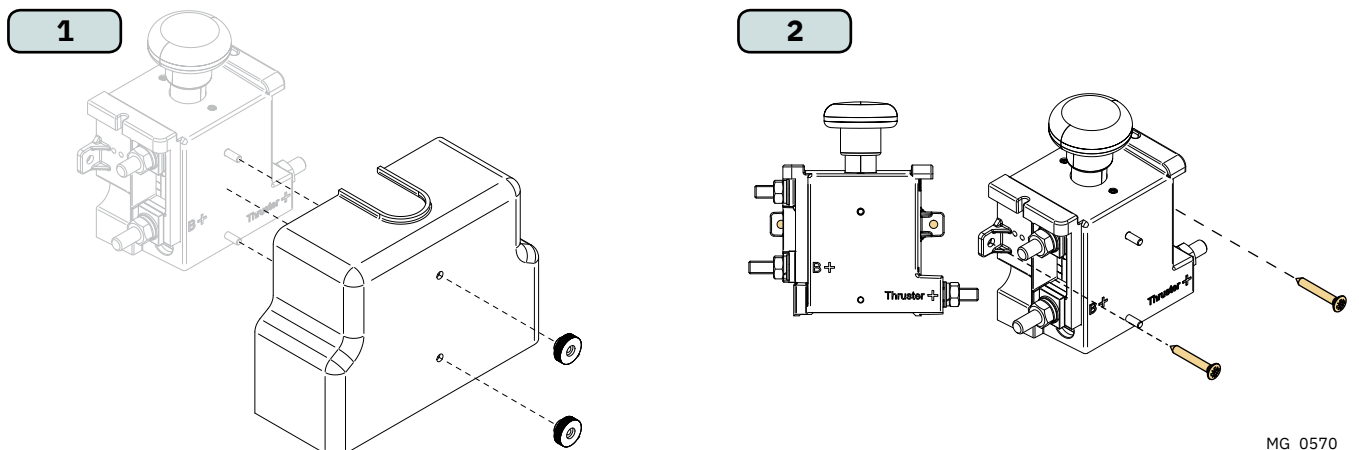

Installing the fuse and battery cable(s).

1. Remove the nuts and the washers.
2. Install the fuse. Select fuse type and rating according to recommendations in thruster installation manual.
3. Assemble the washers, battery cable(s) and end washer and nuts. Select fuse type and rating according to recommendations in thruster installation manual.
4. Tighten the nut with the recommended torque. The bolts are made of brass and too high torque can damage the threads.

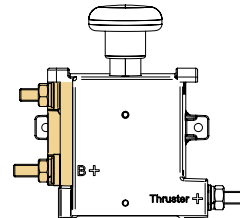

Fitting the thruster cable(s).

5. Remove the nuts and washers.
6. Fit the cable(s) to the bolt and assemble washers and nut.
7. Tighten the nut with the recommended torque.

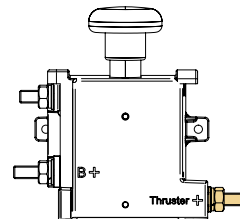

Manual override button.

8. Pull OUT for ON.
9. Push IN for OFF.
10. Leave the switch in ON position when on-board.
11. Ensure the switch is in the OFF position when leaving the boat for long periods or when installing or servicing the thruster system.

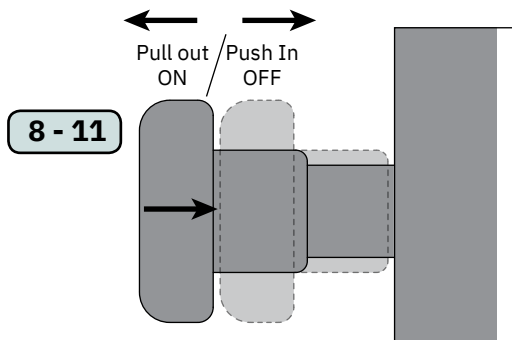
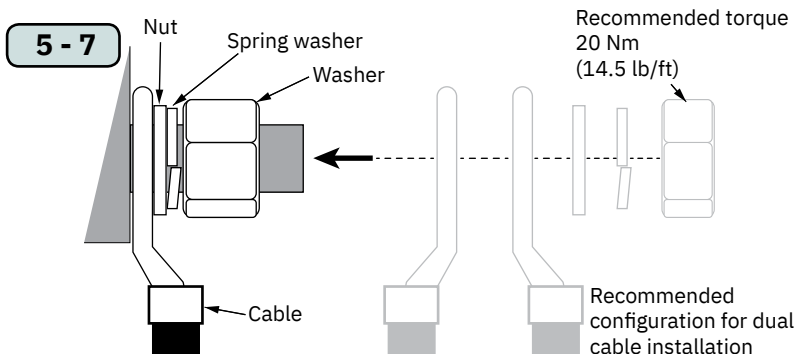
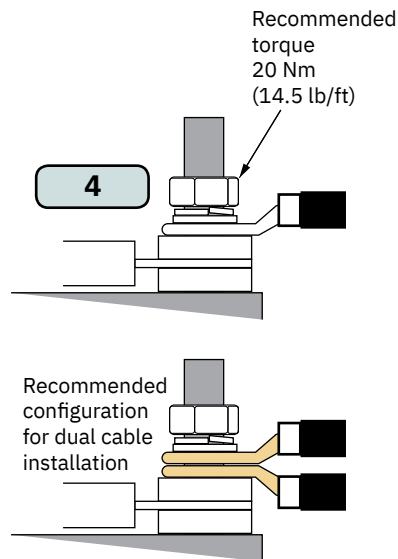
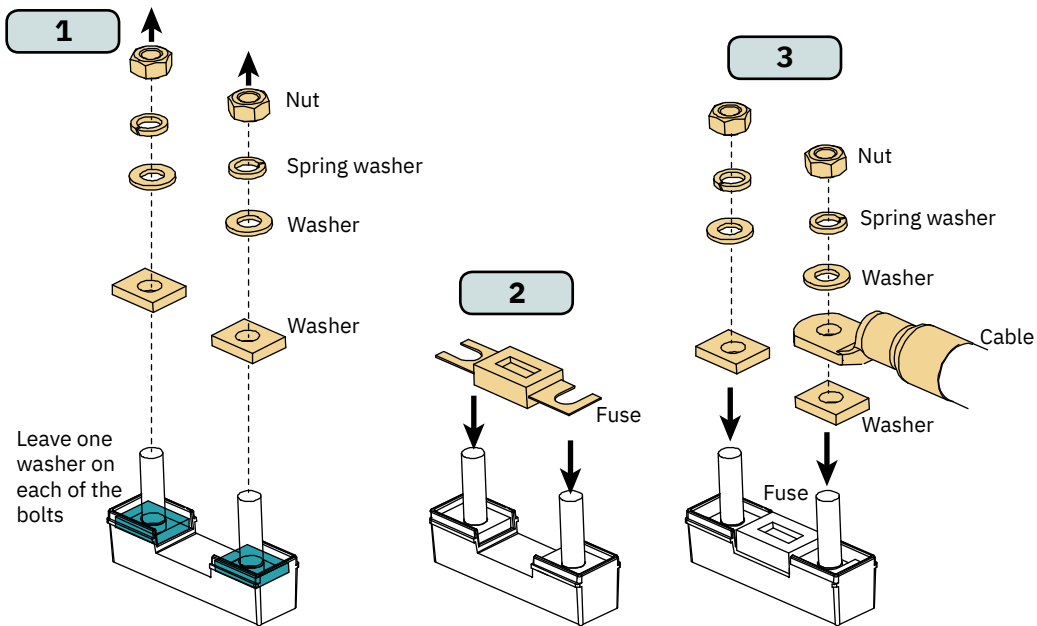
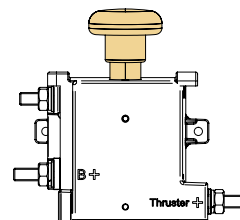

! Please refer to the graphic for special considerations relating to your model !

ON/ OFF configuration

Use a 4-lead control cable between the thruster and the automatic main switch. **(NB: Only 3 leads are used, The red wire is not connected into the automatic main switch.)**

Proportional configuration

Use 5-lead control cables between the automatic main switch and control panels. **(NB: use 5-lead Y-connectors to branch off to all controls fitted.)**

Refer to the table in the thrusters manual for deciding the main cable sizes.

WARNING

Check the following with the main switch is set to off :

After all electrical connections have been completed check with an ohm meter that there is no electrical connection between

1. electro-motor flange and the positive terminal on the motor
2. electro-motor flange and the battery negative terminal on the motor

If unsure contact skilled personnel.

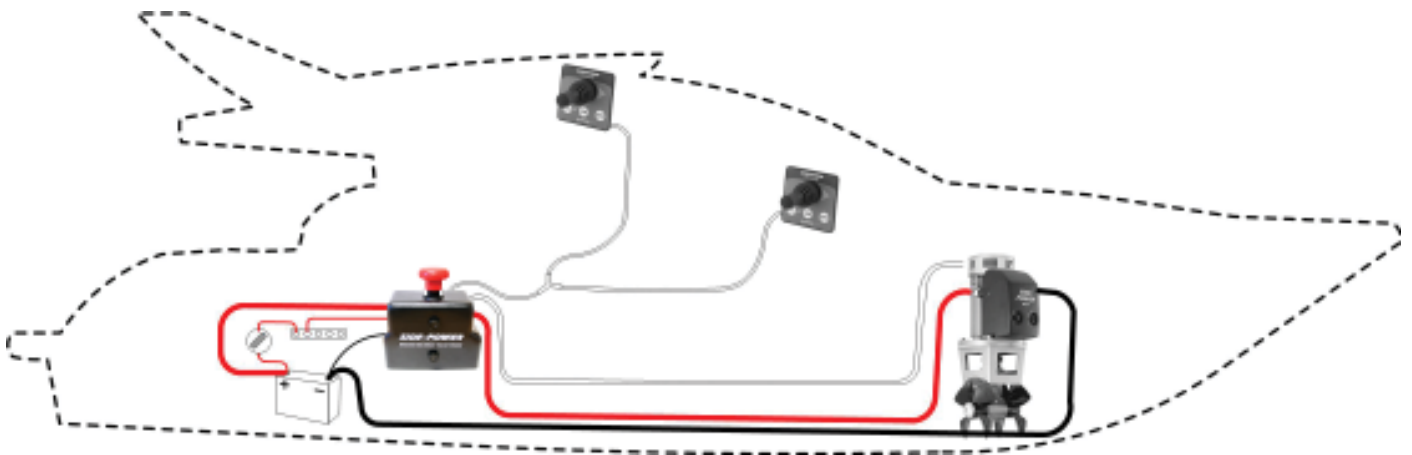

Single Thruster Technical Wiring Diagram

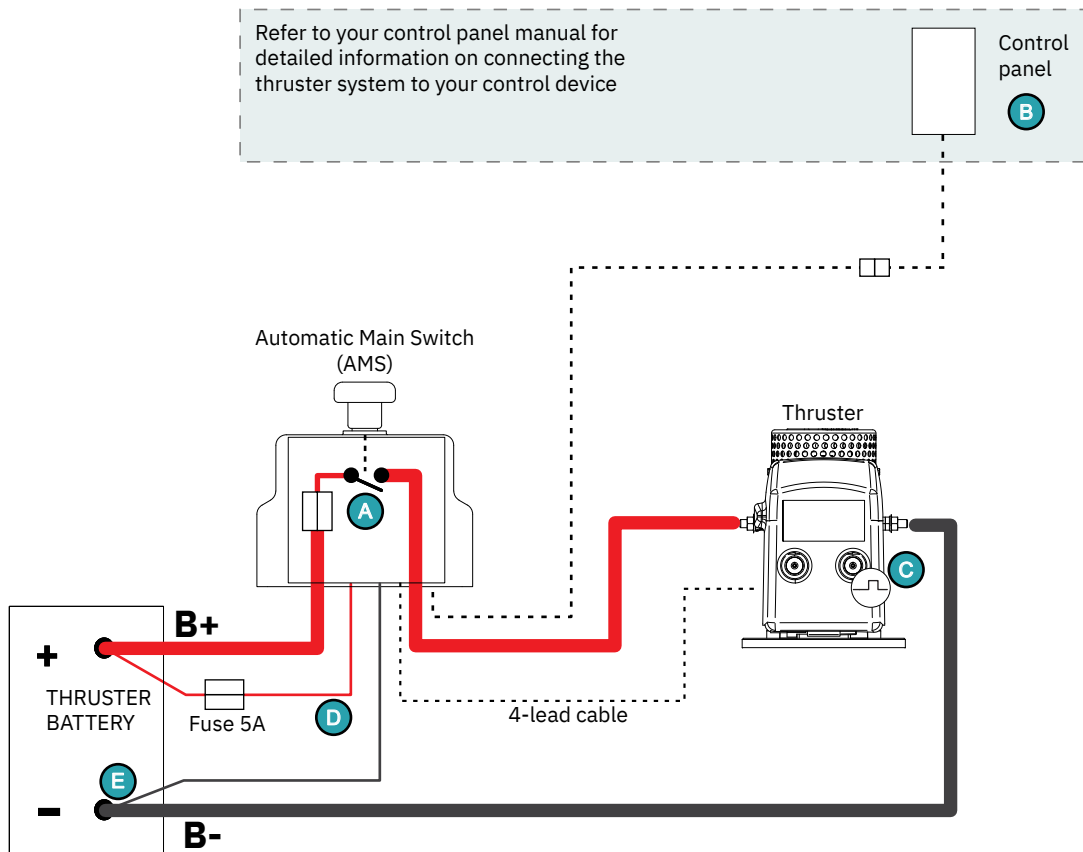

- A** Main switch with fuse, 12 or 24V version.
Select fuse size according to recommendation in thruster installation manual.
- B** ON/OFF thruster control panel.
- C** Thermal switch built into the thruster motor.
- D** Supply for the solenoid with fuse for protection.
- E** Battery voltage according to voltage ratings of thruster motor.

Dual Thruster Technical Wiring Diagram

Refer to your control panel manual for detailed information on connecting the thruster system to your control device

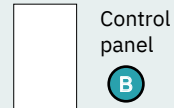

Y-Connector

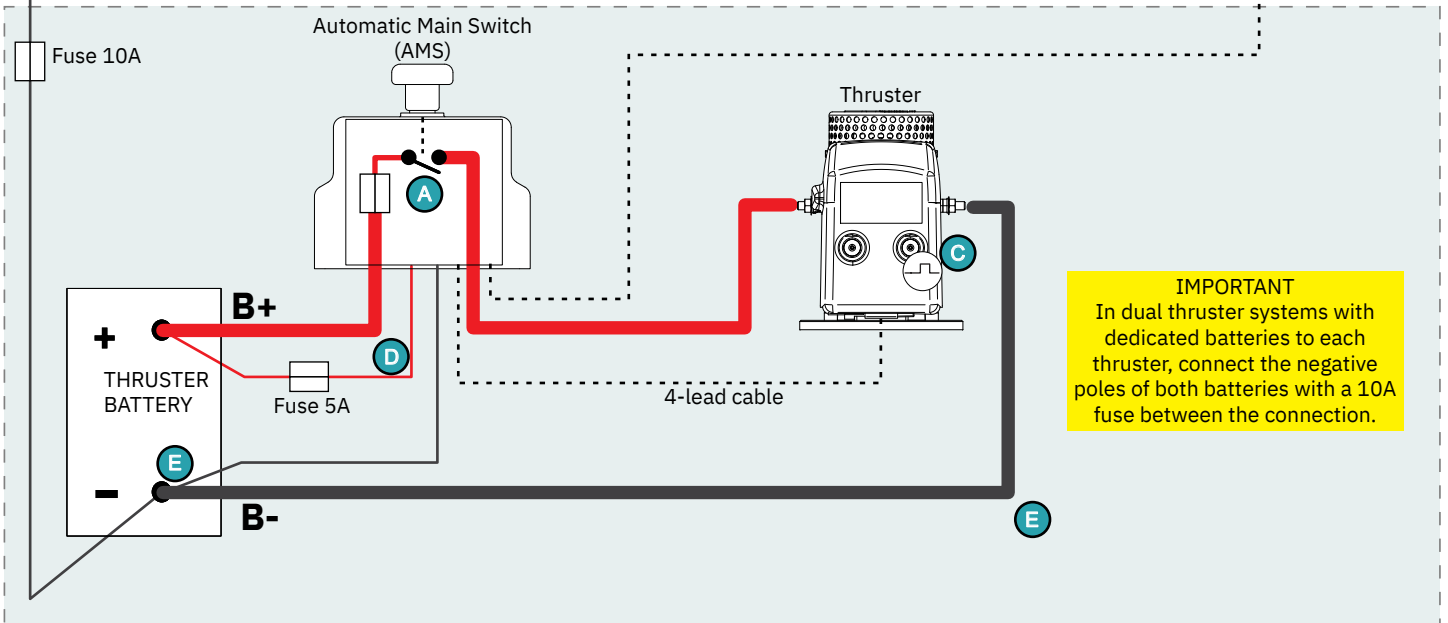
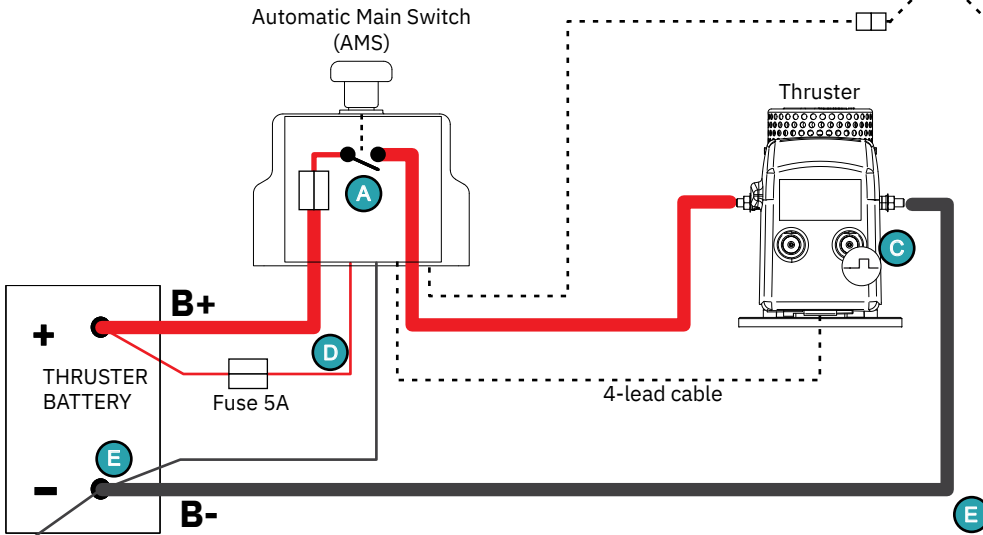

IMPORTANT
In dual thruster systems with dedicated batteries to each thruster, connect the negative poles of both batteries with a 10A fuse between the connection.

IMPORTANT

Check the following with the main switch in the off position

After all electrical connections have been completed check with an ohm meter that there is no electrical connection between electro motor body and positive terminal on the motor and between the electro motor body and the negative (A1) terminal on the motor. If you feel unsure about how to perform this check, contact skilled personnel for guidance

- A** Main switch with fuse, 12 or 24V version. Select fuse size according to recommendation in thruster installation manual.
- B** ON/OFF thruster control panel.
- C** Thermal switch built into the thruster motor.
- D** Supply for the solenoid with fuse for protection.
- E** Battery voltage according to voltage ratings of thruster motor.

Service/ maintenance

on all-electric equipment regularly Ensure:

- Equipment is clean and dry.
- Ensure all cable and other connections are tight and without signs of excessive heat or corrosion.

Troubleshooting

The control panel will not activate:

- Ensure the automatic main switch receives positive feed over its red thin lead.
(NB: If this goes over another main switch in the boat, make sure that this is ON.)
- Check the internal overheat switch (bi-metal switch on the circuit board) in the automatic main switch has not opened.
(NB: It automatically resets if it is open while the main switch is cold, contact your nearest Sleipner service for assistance.)
- Check 5A fuse installed on the red positive cable to the automatic main switch.
- Check the overheat switch in the electro motor has not blown due to excessive heat.
- Check all control cable connections against the wiring diagrams in the thrusters manual are correct.

The control panel activates, but the thruster will not run:

- Ensure the manual over-ride knob is in "ON" position (pulled out).
- Check that the main power fuse in the automatic main switch is not blown.
(NB: if so, ensure that it is the right size. If it is the correct size but the fuse continues to blow, the reason for this must be identified.)
- Check the main switch activates when the control panel is activated. If not, check the wiring, especially that you have a constant separate negative feed (thin black lead) and the control panel is feeding a positive into the yellow lead.
- Check there is power supplied to the thruster. If it is not while the previous points are checked OK, the main cables must be checked.
- If there is power at the thruster, measure the voltage at the main battery cable connection points into the thruster while running the thruster.
(NB: If below 8,5V (12V system) or 16V (24V system) Check the batteries and main cables to find the reason for the voltage drop.)

Read the troubleshooting guide in the thrusters manual.

If you are unable to identify and resolve the problem, contact the nearest Sleipner service point for assistance. Have the notes from your troubleshooting handy to inform the service person of what you have already checked and observed.

Find your local professional dealer from our certified worldwide network for expert service and support. visit our website www.sleipnergrou.com/support

Product Spare Parts and Additional Resources

For additional supporting documentation, we advise you to visit our website www.sleipnergrou.com and find your Sleipner product.

Warranty statement

1. Sleipner Motor AS (The “Warrantor”) warrants that the equipment (parts, materials, and embedded software of products) manufactured by the Warrantor is free from defects in workmanship and materials for purpose for which the equipment is intended and under normal use and maintenance service (the “Warranty”).
2. This Warranty is in effect for two years (Leisure Use) or one year (Commercial and other Non-leisure Use) from the date of delivery/purchase by the end user, with the following exceptions;
 - (a) For demonstration vessels, or vessels kept on the water, the dealer is considered as the end user from 6 months after their launch of the vessel;
 - (b) The warranty period starts no later than 18 months after the first launch of the vessel.
 Please note that the boat manufacturer and dealer must pay particular attention to correct maintenance and service both by the products manuals as well as general good practice for the location the boat is kept in the period the boat is in their care. In cases where the 6 and 18 months grace periods for boat builders and dealers are passed, it is possible to obtain a full warranty upon inspection and approval of the warrantor or such representative.
3. Certain parts, classified as wearable or service parts, are not covered by the warranty. A failure to follow the required maintenance and service work as described in the product manual render all warranty on parts or components directly or indirectly affected by this void. Please also note that for some parts, time is also a factor separately from actual operational hours.
4. This Warranty is transferable and covers the equipment for the specified warranty period.
5. The warranty does not apply to defects or damages caused by faulty installation or hook-up, abuse or misuse of the equipment including exposure to excessive heat, salt or fresh water spray, or water immersion except for equipment specifically designed as waterproof.
6. In case the equipment seems to be defective, the warranty holder (the “Claimant”) must do the following to make a claim:
 - (a) Contact the dealer or service centre where the equipment was purchased and make the claim. Alternatively, the Claimant can make the claim to a dealer or service centre found at www.sleipnergrou.com. The Claimant must present a detailed written statement of the nature and circumstances of the defect, to the best of the Claimant’s knowledge, including product identification and serial nbr., the date and place of purchase and the name and address of the installer. Proof of purchase date should be included with the claim, to verify that the warranty period has not expired;
 - (b) Make the equipment available for troubleshooting and repair, with direct and workable access, including dismantling of furnishings or similar, if any, either at the premises of the Warrantor or an authorised service representative approved by the Warrantor. Equipment can only be returned to the Warrantor or an authorised service representative for repair following a pre-approval by the Warrantor’s Help Desk and if so, with the Return Authorisation Number visible postage/shipping prepaid and at the expense of the Claimant.
7. Examination and handling of the warranty claim:
 - (a) If upon the Warrantor’s or authorised service Representative’s examination, the defect is determined to result from defective material or workmanship in the warranty period, the equipment will be repaired or replaced at the Warrantor’s option without charge, and returned to the Purchaser at the Warrantor’s expense. If, on the other hand, the claim is determined to result from circumstances such as described in section 4 above or a result of wear and tear exceeding that for which the equipment is intended (e.g. commercial use of equipment intended for leisure use), the costs for the troubleshooting and repair shall be borne by the Claimant;
 - (b) No refund of the purchase price will be granted to the Claimant, unless the Warrantor is unable to remedy the defect after having a reasonable number of opportunities to do so. In the event that attempts to remedy the defect have failed, the Claimant may claim a refund of the purchase price, provided that the Claimant submits a statement in writing from a professional boating equipment supplier that the installation instructions of the Installation and Operation Manual have been complied with and that the defect remains.
8. Warranty service shall be performed only by the Warrantor, or an authorised service representative, and any attempt to remedy the defect by anyone else shall render this warranty void.
9. No other warranty is given beyond those described above, implied or otherwise, including any implied warranty of merchantability, fitness for a particular purpose other than the purpose for which the equipment is intended, and any other obligations on the part of the Warrantor or its employees and representatives.
10. There shall be no responsibility or liability whatsoever on the part of the Warrantor or its employees and representatives based on this Warranty for injury to any person or persons, or damage to property, loss of income or profit, or any other incidental, consequential or resulting damage or cost claimed to have been incurred through the use or sale of the equipment, including any possible failure or malfunction of the equipment or damages arising from collision with other vessels or objects.
11. This warranty gives you specific legal rights, and you may also have other rights which vary from country to country.

Patents

At Sleipner we continually reinvest to develop and offer the latest technology in marine advancements. To see the many unique designs we have patented visit our website www.sleipnergrou.com/patents

© **Sleipner Group**, All rights reserved
The information given in the document
was right at the time it was published.
However, Sleipner Group cannot
accept liability for any inaccuracies or
omissions it may contain. Continuous
product improvement may change the
product specifications without notice.
Therefore, Sleipner Group cannot accept
liability for any possible differences
between product and document.

**Register your product and learn more
at www.sleipnergroun.com**



SLEIPNER GROUP

P.O. Box 519

N-1612 Fredrikstad

Norway

www.sleipnergroun.com

Made in Norway

