



## BC-1224-10 Charger Manual

### 1. FEATURES

- ❑ Microcontroller based 4-Stage 3-Level adaptive charging
- ❑ Fully automatic without intervention
- ❑ DC input for charging 24V batteries
- ❑ Auto power on/off depended on input voltage
- ❑ Output short circuit protection
- ❑ Input low voltage and high voltage protections
- ❑ Informative panel LED indications

### 2. SPECIFICATIONS

Input Voltage	10 – 15V	
Battery Voltage	24V	
Charging Current	10A (Peak)	
Auto Power On/Off	Power On at 13.5V (+/-2%) Power Off at 12.5V (+/-2%)	
Input Fuse	40A	
Protections	Input Polarity	Yes
	Low Input Voltage	< 9.5V
	High Input Voltage	> 15.5V
	Over Temperature	Internal 80 °C
	Output Short Circuit	Yes
Cooling	Controlled DC Fan	
Operating Temperature	0 – 55 °C	
Dimensions(mm)	200 (W) x 205 (L) x 70 (H)	
Weight	1.5Kg	





### 3. INSTALLATION & MOUNTING

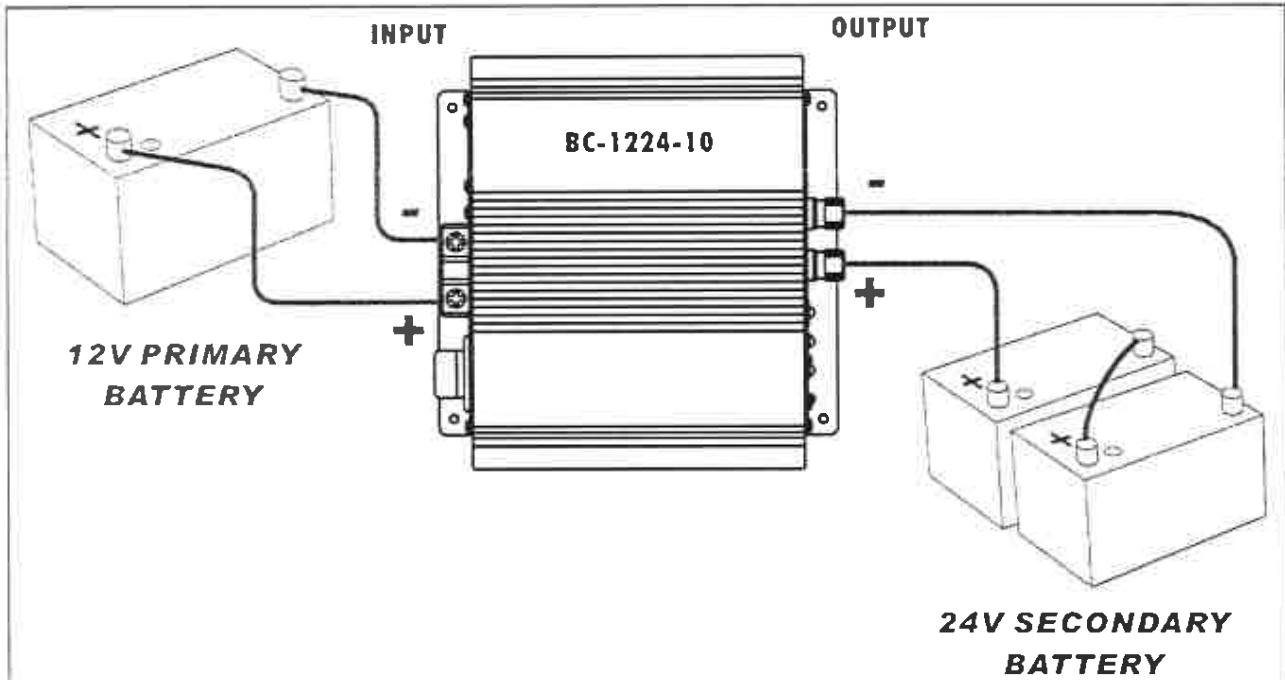
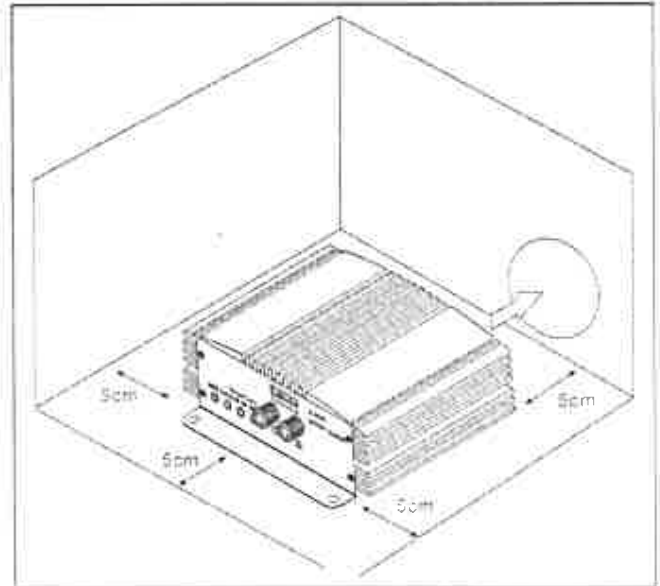
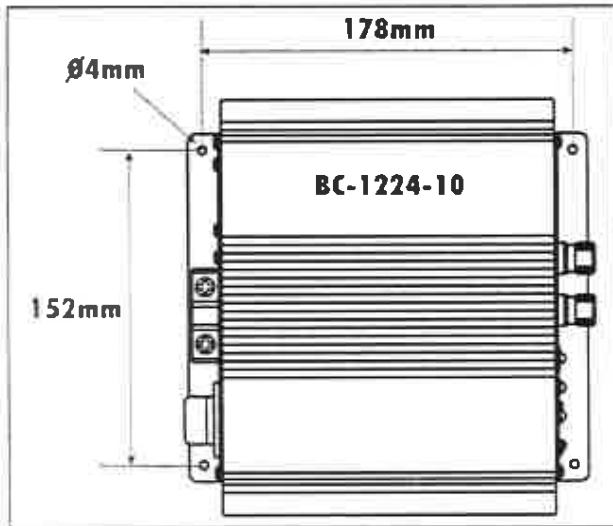

- ✓ Mount the charger such that there is no blocking of the ventilation holes at the rear panel
- ✓ Ensure the charger is mount securely
- ✓ Do not install the charger near any heat source or direct sunlight and water
- ✓ Use sufficient gauge size cables for both input and output
- ✓ Always fasten cables securely
- ✓ Ensure good ventilation



#### 4. OPERATION

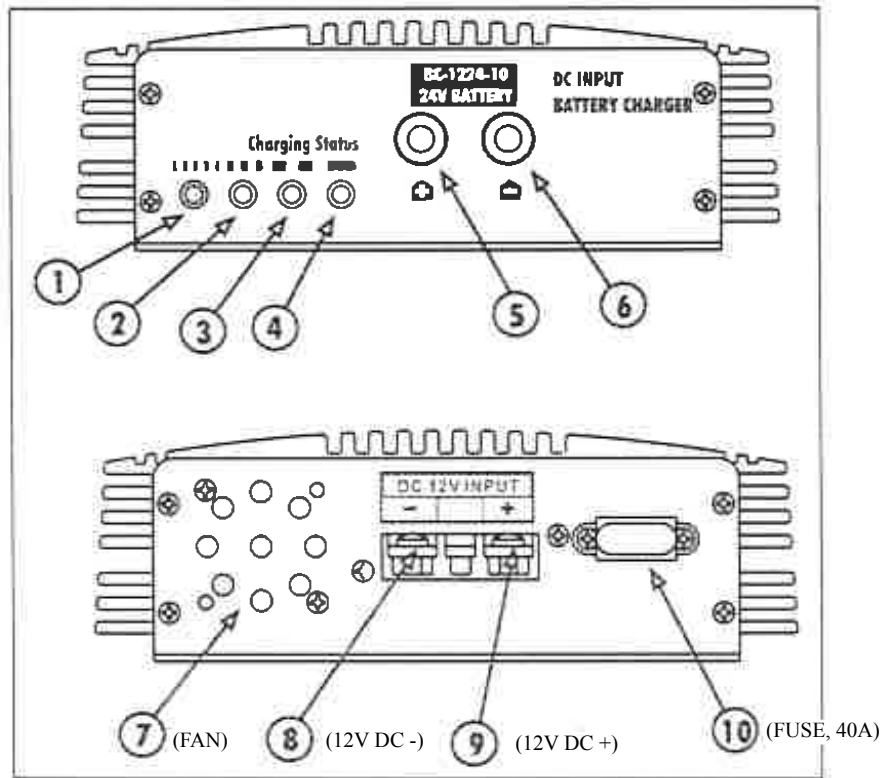

●	Tickle Charge Red LED	●	“-” Black Output Binding Post
●	Bulk Charge Red LED	●	Ventilation Holes (Fan Behind)
●	Over Charge Yellow LED	●	DC12V “-” Input Terminal
●	Float Charge Green LED	●	DC12V “+” Input Terminal
●	“+” Red Output Binding Post	●	Blade Type Car Fuse Holder

- (1) Connect DC 12V to the terminal on the rear panel. (Cable size should be at least AWG#12 for full capacity operation)
- (2) Charger turns on when the input voltage is above 13.5V and it turns off when the input voltage is below 12.5V.
- (3) Panel LEDs flash in cyclic manner (standby state) after power on.
- (4) Connect the battery to the charger. The charger detects and charges the battery according to the charging condition of the battery automatically.
- (5) Buzzer sounds whenever there is a change in status or alarm.
- (6) Charging is finished at float charge (green LED flashes).



**5. INDICATIONS**

Status	Completion	Charging Status LEDs			
		Red	Red	Yellow	Green
Standby	---	Cyclic			
Trickle	30%	Cyclic		Off	Off
Bulk	60%	Off	Cyclic		Off
Over Charge	90%	Off	Off	Cyclic	
Float	100%	Off	Off	Off	Flash
Low Battery Voltage	Alarms	Flash	Off	Off	Off
High Battery Voltage		Off	Flash	Off	Off
Low Input Voltage		Flash	Off	On	Off
High Input Voltage		Off	Flash	On	Off
Over Temperature		Off	Off	Flash	Off

\* All alarms and protections are auto resume

**6. REMEDIES**

Symptom	Recommended Action
No indicator is on or they are not in standby cyclic mode after power on	(1) Check fuse. (2) Check input power cable connection (3) Need repairing.
Input low/high voltage alarm when power on	Check the input voltage range.
Charger is still in standby mode even the battery has been connected	(1) Check the cables. (2) Faulty battery.
Always low input voltage alarm when the charge at bulk charge mode	(1) Check the stability of the DC input source during charging process. (2) Use large gauge size input cable.
After battery is connected, Trickle & Bulk LEDs flash in cyclic mode for a while and low/high battery alarm rises	Check the battery voltage
After battery is connected, Trickle & Bulk LEDs flash in cyclic mode for a long time. Or It always jumps back to Trickle LED from O or F repeatedly	Aged battery with very large leakage current. Need to change the battery.
The charger always jumps back from float charge to bulk charge after it stays at float charge for some time	(1) The leakage current of the battery is large. (2) Check if there is any loading on the battery.
The charger jumps to float charge after a discharged battery is connected	Aged battery with large internal resistance. Need to change the battery.
No flashing LED or only one LED is on	There is always at least one LED flashing. Otherwise the charger needs repairing.

